

Meantime AV30-AV31

Anderssen & Voll

2025

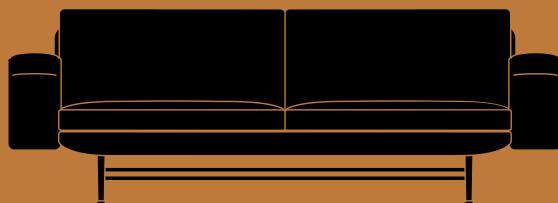

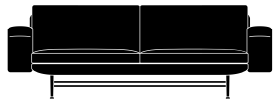

W: 194 cm / 76 in
D: 85 cm / 33 in

H: 70 cm / 28 in
Seat H: 41 cm / 16 in
Seat D: 56 cm / 22 in
Armrest H: 53 cm / 21 in

Meantime^{AV30} Anderssen & Voll 2025

Product description

Sofa

Environment

Indoor

Material

Plywood frame, HR foam, polyester wadding, steel, polished or power-coated aluminium. This product has not been treated with any biocides.

Production process

The plywood frame is upholstered with foam and a textile cover. The upholstered cushions are made from HR foam with duvets filled with silicone fibers and attached to the frame with velcro. The armrests are made of a steel construction which is wrapped in hard foam and attached to the frame using a bolt connection. The legs are made of cast aluminium which is either polished or powder-coated.

Variants

Warm Black or Polished Aluminium legs
Available in a variety of fabrics and COM

COM - Material Consumption

Fabric usage: 6.4 meters based on 140 cm roll
Leather usage: 13.2 m²
COM must be approved by &Tradition to ensure suitability for upholstery

Dimensions

W: 194 cm / 76 in
H: 70 cm / 28 in
D: 85 cm / 33 in
Seat H: 41 cm / 16 in
Seat D: 56 cm / 22 in
Armrest H: 53 cm / 21 in

Weight

40 kg

Certifications



FSC® Mix 70%

Gliders

Plastic gliders as standard

Manufacturer

Produced in Poland by Trioline Polska Sp. z o. o.

Cleaning Instructions

Please see our [Maintenance & Care instructions here](#)



Ecriture 0210



Fiord 0571



Hallingdal 0220

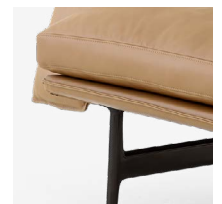

Noble Aniline Leather
Cognac



W: 237 cm / 93 in
D: 85 cm / 33 in

H: 70 cm / 28 in
Seat H: 41 cm / 16 in
Seat D: 56 cm / 22 in
Armrest H: 53 cm / 21 in

Meantime AV31

Anderssen & Voll

2025

Product description

Sofa

Environment

Indoor

Material

Plywood frame, HR foam, polyester wadding, steel, polished or power-coated aluminium. This product has not been treated with any biocides.

Production process

The plywood frame is upholstered with foam and a textile cover. The upholstered cushions are made from HR foam with duvets filled with silicone fibers and attached to the frame with velcro. The armrests are made of a steel construction which is wrapped in hard foam and attached to the frame using a bolt connection. The legs are made of cast aluminium which is either polished or powder-coated.

Variants

Warm Black or Polished Aluminium legs
Available in a variety of fabrics and COM

COM - Material Consumption

Fabric usage: 8 meters based on 140 cm roll
Leather usage: 14.9 m²
COM must be approved by &Tradition to ensure suitability for upholstery

Dimensions

H: 70 cm / 28 in
W: 237 cm / 93 in
D: 85 cm / 33 in
Seat H: 41 cm / 16 in
Seat D: 56 cm / 22 in
Armrest H: 53 cm / 21 in

Weight

50 kg

Certifications



FSC® Mix 70%

Gliders

Plastic gliders as standard

Manufacturer

Produced in Poland by Trioline Polska Sp. z o. o.

Cleaning Instructions

Please see our [Maintenance & Care instructions](#) [here](#)



Ecriture 0210



Fiord 0571



Hallingdal 0220

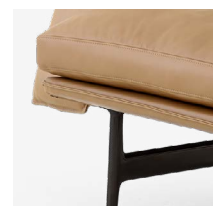

Noble Aniline Leather
Cognac

Recycling & Disassembly

Meantime AV29-AV31

RECYCLING

The Meantime sofa is built to last, and we hope that your Meantime will serve you for many years. The sofa is covered with an high quality fabric which can be separated from its base. All fabric, foam, wooden and metal parts can be separated and delivered to a suitable recycling station.

SPARE PARTS

To purchase spare parts for your Meantime sofa, please write to our sales support team at info@andtradition.com with your query.

5 YEAR WARRANTY

&Tradition provides a 5-year warranty with every Meantime sofa, which covers faults which were present at the time of purchase, or which have occurred as a result of a manufacturing defect. The warranty is valid from the date stated on the original invoice.

SAFETY PRECAUTIONS

- Do not disassemble alone
- Be aware of the the risk of crushing fingers or other body parts
- The screws might be oiled, so be aware not to get any oil on to the upholstery

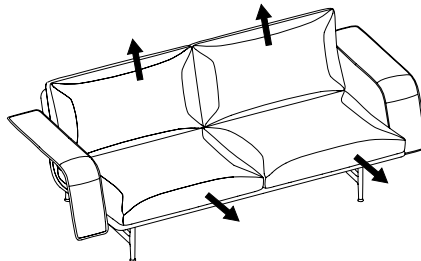

DISASSEMBLY

1. Remove seat and back cushions from the sofa before starting the disassembly.

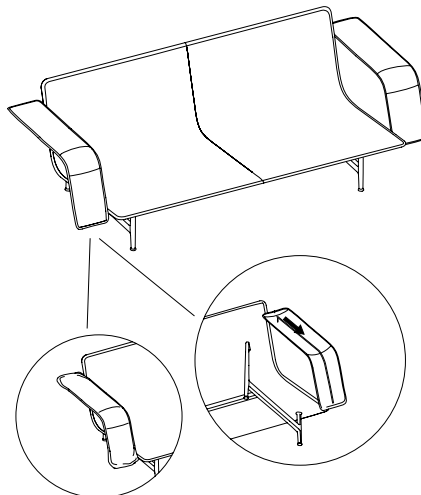

2. Identify the zipper located on the bottom side of the armrests and carefully unzip it to open the fabric. Gently pull the fabric sideways, partially removing it to expose the internal structure of the armrests.

NB: Don't try to remove the fabric completely before completing step 3 and 4.

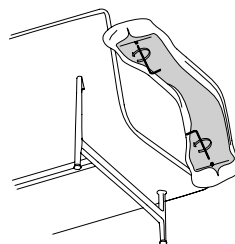

3. Insert the Allen key into the top screw on the bottom side of the armrest and turn counterclockwise to remove it. Repeat the process for the bottom screw.

Recycling & Disassembly

Meantime AV29-AV31

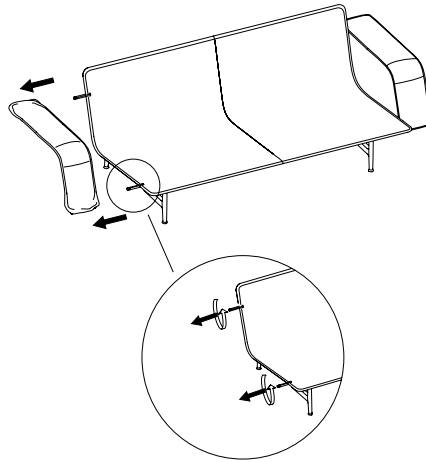

DISASSEMBLY

4. Grasp each armrest firmly and gently pull it away from the main frame. If there is any resistance, check for the screws (Step 3) that need to be removed.

5. Using your hands, grasp each metal shaft firmly and turn counterclockwise to unscrew it from the frame. No additional tools should be necessary for this step.

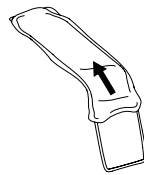

6. With the armrests already detached, carefully finish removing the fabric from the armrest. Once fully separated, set the fabric aside for recycling or disposal.

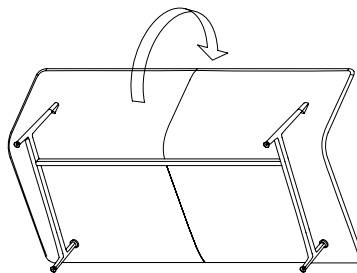

7. To continue the disassembly, flip the sofa upside down. You need assistance of an additional person to safely perform this action.

Recycling & Disassembly

Meantime AV29-AV31

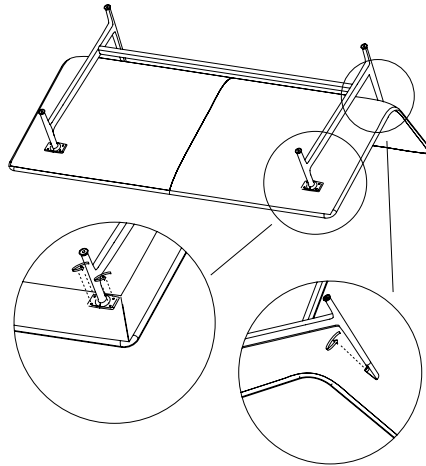

DISASSEMBLY

8. Unscrew the 4 screws from each front leg completely, and loosen the screws attached to the backrest.

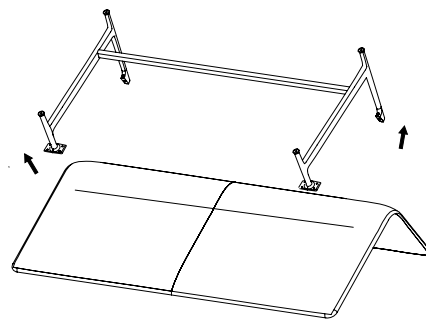

9. Separate the metal base from the frame.

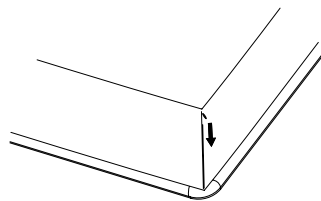

10. Identify the zippers positioned at the backside corners of the seating area. Gently pull the zipper tab to loosen the cover. Repeat this step for the other corner.

Recycling & Disassembly

Meantime AV29-AV31

DISASSEMBLY

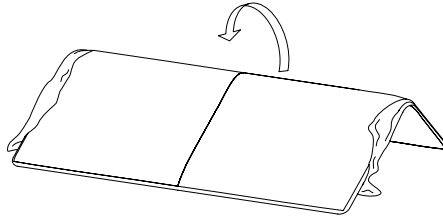

11. Proceed with the removal of the textile cover from the seating area. Please be aware that you may need to flip the frame once more to proceed.

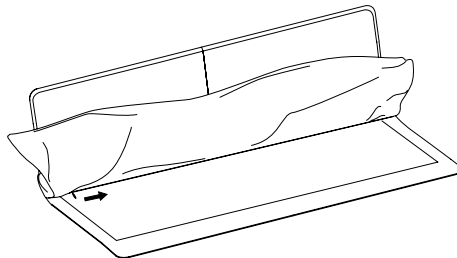

12. Locate and unzip the zipper in the seat bend to completely release the cover from the frame.

NB: To clean the cover, you need to stop at this step. After cleaning, follow the steps in reverse order to reassemble the sofa. If you wish to fully disassemble the sofa into its components, please continue with the following steps.

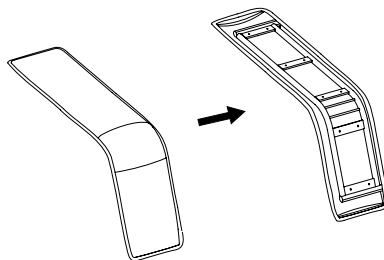

13. Carefully peel away the foam from the metal frame. You may need to gently pry it off or use a tool like a putty knife to separate stubborn areas. Dispose both the foam and the metal frame in accordance with local recycling or waste disposal guidelines.

Recycling & Disassembly

Meantime AV29-AV31

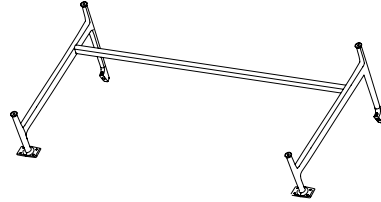

DISASSEMBLY

14. Finally, separate the frame into its metal, foam, and wooden components. Dispose the materials in accordance with local recycling or waste disposal guidelines.

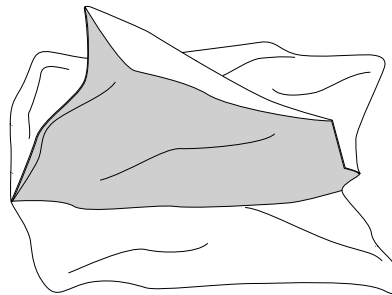
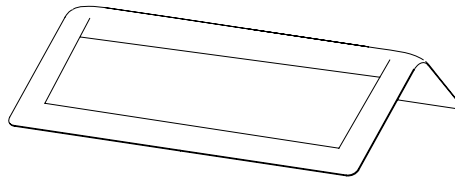

15. Remove the wadding from the textile by carefully cutting it with a knife or pulling it off by hand.