

FontanaArte

MILANO 1932

News
2023 - 2024

- 4 **THALEA**
6 - SOSPENSIONE / SUSPENSION
10 - Paolo Rizzato e Francesco Librizzi
- 12 **BLOM** by Parley for Oceans
- TAVOLO / TABLE
- 14 **BIANCA**
16 - TAVOLO / TABLE
17 - PARETE E PLAFONE / WALL AND CEILING
18 - SOSPENSIONE / SUSPENSION
- 20 **IO**
22 - PARETE / WALL
29 - Claesson Koivisto Rune
- 24 **CAMEO**
26 - TAVOLO / TABLE
29 - Claesson Koivisto Rune
- 30 **UOVO**
32 - TAVOLO RIC. / TABLE REC.
33 - SOSPENSIONE / SUSPENSION
34 - Ben Swildens
- 36 **FONTANELLA**
38 - PARETE E PLAFONE / WALL AND CEILING
40 - SOSPENSIONE / SUSPENSION
43 - Federico Peri
- 44 **LUNAIRE**
45 - PARETE E PLAFONE / WALL AND CEILING
47 - Ferréol Babin
- 48 **NASKA XL**
50 - TERRA / FLOOR
50 - DA ESTERNO / OUTDOOR
51 - Historical Archive
- 52 **FONTANA**
53 - VASO / VASE
- 56 **FRENESI**
58 - PARETE / WALL
61 - StudioLucaGuadagnino
- 62 **THEA**
64 - TAVOLO / TABLE
66 - TERRA / FLOOR
67 - PARETE E PLAFONE / WALL AND CEILING
69 - SOSPENSIONE / SUSPENSION
71 - Gabriele e Oscar Buratti
- 72 **TUTTI**
74 - SOSPENSIONE / SUSPENSION
81 - Matilde Cassani
- 82 **OORT**
84 - TAVOLO / TABLE
86 - TERRA-CIELO / FLOOR TO CEILING
88 - PARETE E PLAFONE / WALL AND CEILING
90 - PLAFONE / CEILING
92 - SOSPENSIONE / SUSPENSION
98 - DA ESTERNO / OUTDOOR
103 - Jacopo Roda

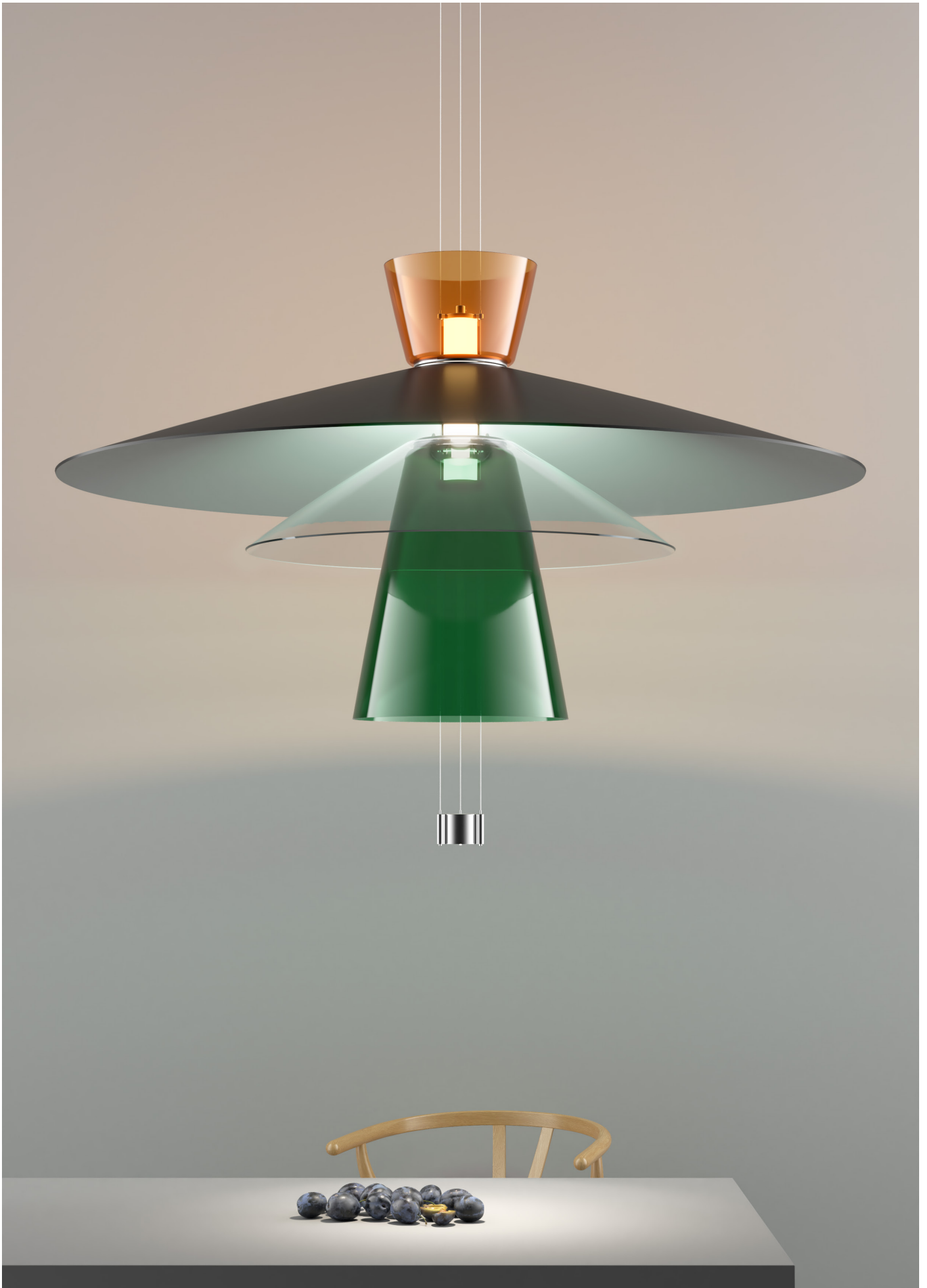

The Thalea project comes from the passion for light and colour of Paolo Rizzatto and Francesco Librizzi. A series of lampshades in coloured borosilicate glass and aluminum that, can be composed in multiple configurations, inspired by the proportions of masterpieces of Italian Renaissance art.

The lampshades vary in size and width and are conical in shape with a slight curvature that softens the silhouette. The colour palette is wide and ranges from warm to cool tones, combined in different compositions in harmony or contrast. Two light sources, dimmable LED that diffuses ambient light through the coloured glass and a spot light to illuminate the surfaces directly.

Thalea recalls the timeless spirit balanced between art and industry that has always inspired FontanaArte's contemporary production. A modular lamp that shapes the dreams of those who choose and compose it.



Dalla passione per la luce e il colore di Paolo Rizzatto e Francesco Librizzi nasce il progetto *THALEA*. Una serie di paralumi in vetro borosilicato colorato e alluminio che, si possono comporre in configurazioni molteplici, ispirate alle proporzioni dei capolavori dell'arte rinascimentale italiana.

I paralumi, di diversa dimensione e ampiezza, sono di forma conica con una leggera bombatura che ne addolcisce la silhouette. La gamma cromatica è ampia e spazia dai toni caldi ai freddi, combinati nelle diverse composizioni in armonia o a contrasto. Due le sorgenti luminose, un LED dimmerabile che diffonde la luce nell'ambientale attraverso i vetri colorati e uno spot per illuminare direttamente le superfici.

Thalea richiama lo spirito senza tempo, in equilibrio tra arte e industria che ispira da sempre la produzione contemporanea di FontanaArte.

Una lampada componibile che dà spazio ai sogni e alle necessità di chi la sceglie.

Lampada a luce diretta e indiretta, a sospensione, struttura in alluminio, diffusori in vetro e in alluminio – diffusori disponibili in 4 forme diverse in vetro colorato e 1 forma in alluminio nera – disponibile con 2 fonti luminose: una diffusa e una spot - LED integrato e dimmerabile – regolabile in altezza.

Pendant lamp with direct and indirect light, aluminium structure, glass and aluminium diffusers - diffusers available in 4 different shapes in coloured glass and 1 shape in black aluminium - available with 2 light sources: one diffuse and one spot - integrated and dimmable LED - height adjustable.



THR44841E210NB

● nero / black

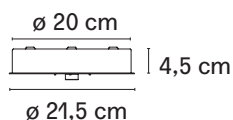

Sorgente luminosa / Light source

THM44841E200AL

● alluminio / aluminum
con 1 ghiera di fissaggio /
with 1 fixing ring

max 2 accessori /
2 accessories max

LED 20W (2700K, CRI >90, 2400Lm)
dimmerabile / dimmable DALI

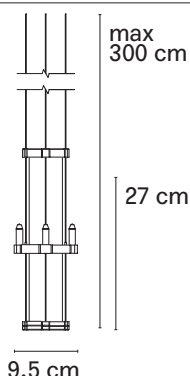

THM44842E200AL

● alluminio / aluminum
con 2 ghiera di fissaggio /
with 2 fixing rings

max 4 accessori /
4 accessories max

LED 20W (2700K, CRI >90, 2400Lm)
dimmerabile / dimmable DALI

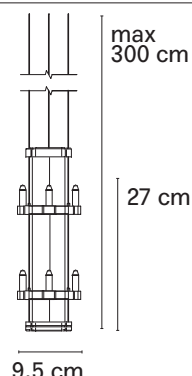

Diffusori in vetro / Glass diffuser

THV448410150..

- AM (ambra / amber)
- RO (rosso / red)
- TR (trasparente / transparent)
- VE (verde / green)
- BL (blu / blue)

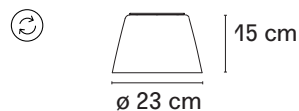

THV448420150..

- AM (ambra / amber)
- RO (rosso / red)
- TR (trasparente / transparent)
- VE (verde / green)
- BL (blu / blue)

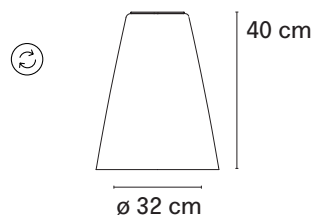

THV448430150..

- AM (ambra / amber)
- RO (rosso / red)
- TR (trasparente / transparent)
- VE (verde / green)
- BL (blu / blue)

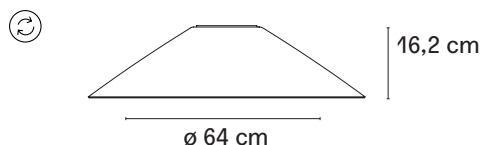

Paralume in metallo / Metal diffuser

THP4484200NEBI

● nero / black

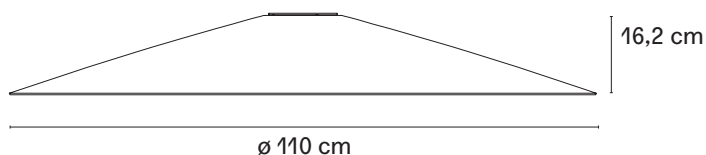

Spot

THS44841E200AL

● alluminio / aluminum

LED 8W (2700K, CRI 90, 1000Lm)
dimmerabile / dimmable DALI

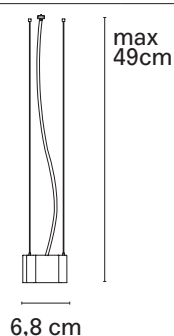

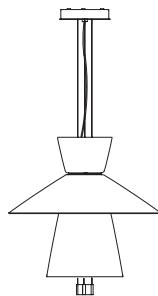
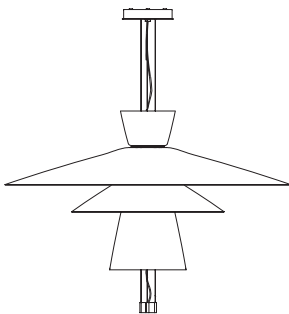
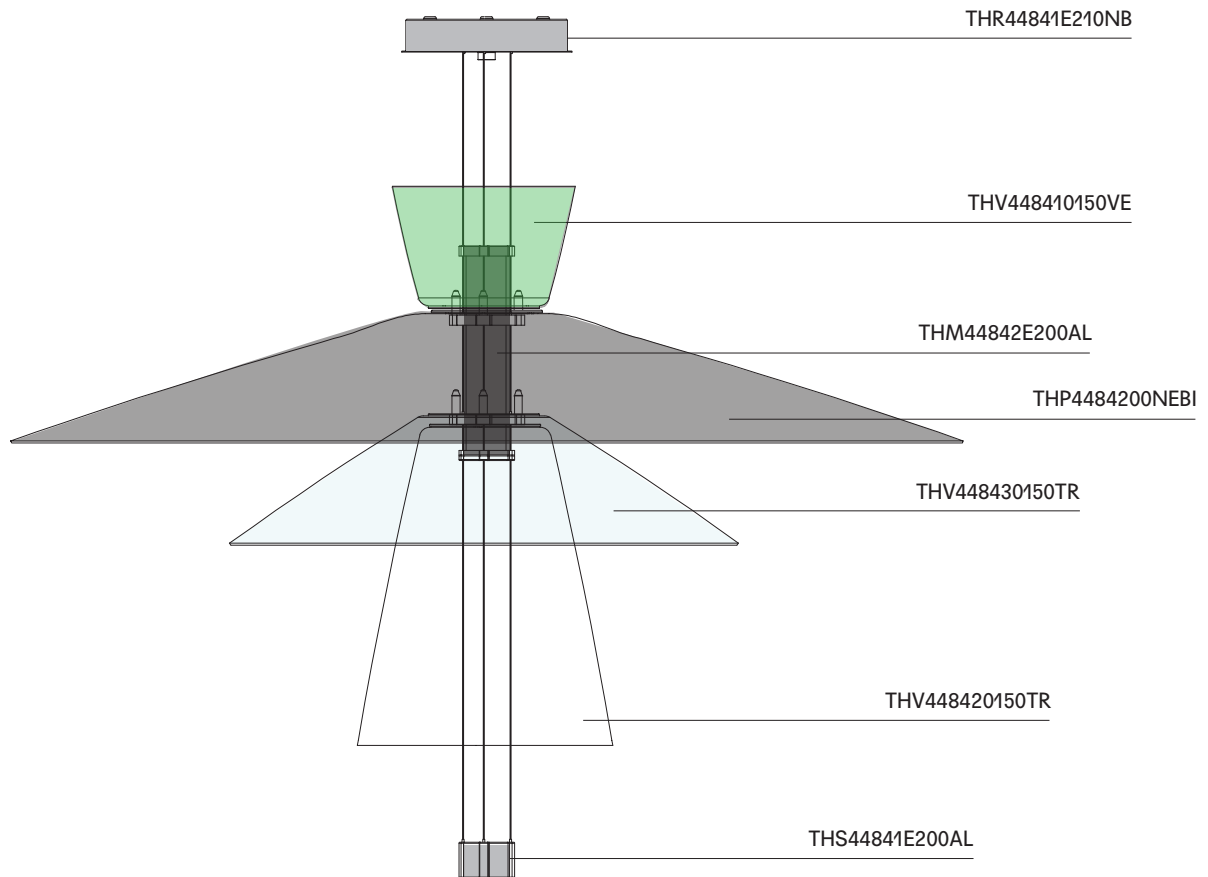

THR44841E210NB
rosone / ceiling

+
THM44842E200AL

corpo luce lineare / linear light body
con 2 ghiera / with 2 fixing rings

+
THV448410150..

diffusore in vetro / glass diffuser d.23 cm



+
THP4484200NEBI

diffusore in metallo / metal diffuser

+
THV448430150..

diffusore in vetro / glass diffuser d.64 cm



+
THV448420150..

diffusore in vetro / glass diffuser d.32 cm



+
THS44841E200AL
spot

THR44841E210NB
rosone / ceiling

+
THM44842E200AL

corpo luce lineare / linear light body
con 2 ghiera / with 2 fixing rings

+
THV448410150..

diffusore in vetro / glass diffuser d.23



+
THV448420150..

diffusore in vetro / glass diffuser d.32 cm



+
THV448430150..
diffusore in vetro d.64



+
THS44841E200AL
spot

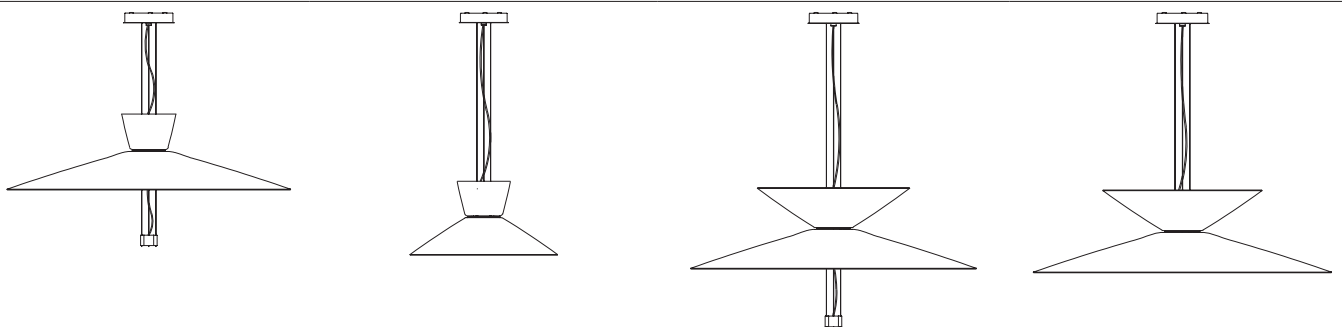
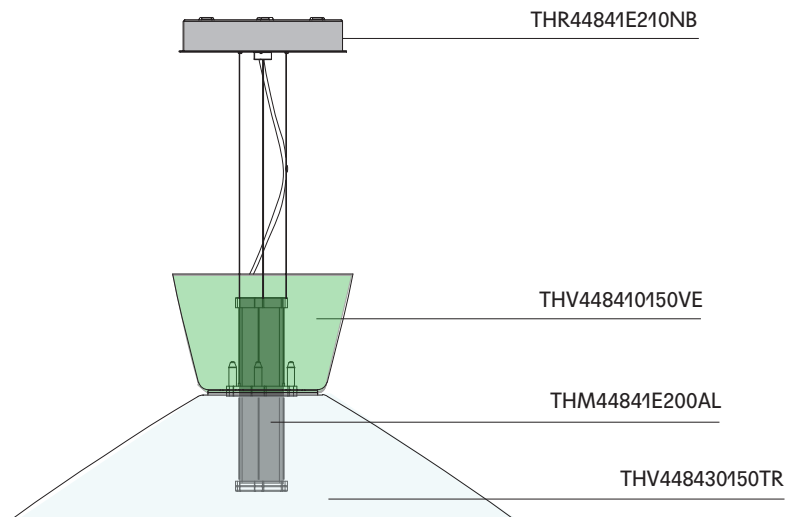

THR44841E210NB
rosone / ceiling

+

THM44841E200AL
corpo luce lineare / linear light body
con 1 ghiera / with 1 fixing ring

+

THV448410150..
diffusore in vetro / glass diffuser d.23 cm

+

THP4484200NEBI
diffusore in metallo / metal diffuser

+

THS44841E200AL
spot

THR44841E210NB
rosone / ceiling

+

THM44841E200AL
corpo luce lineare / linear light body
con 1 ghiera / with 1 fixing ring

+

THV448410150..
diffusore in vetro / glass diffuser d.23

+

THV448430150..
diffusore in vetro / glass diffuser d.64 cm

THR44841E210NB
rosone / ceiling

+

THM44841E200AL
corpo luce lineare / linear light body
con 1 ghiera / with 1 fixing ring

+

THV448430150..
diffusore in vetro / glass diffuser d.64 cm

+

THP4484200NEBI
diffusore in metallo / metal diffuser

+

THS44841E200AL
spot

THR44841E210NB
rosone / ceiling

+

THM44841E200AL
corpo luce lineare / linear light body
con 1 ghiera / with 1 fixing ring

+

THV448430150..
diffusore in vetro / glass diffuser d.64 cm

+

THP4484200BINE
diffusore in metallo / metal diffuser



THR44841E210NB
rosone / ceiling

+

THM44841E200AL
corpo luce lineare / linear light body
con 1 ghiera / with 1 fixing ring

+

THV448410150..
diffusore in vetro / glass diffuser d.23

+

THV448420150..
diffusore in vetro / glass diffuser d.32 cm

+

THS44841E200AL
spot

THR44841E210NB
rosone / ceiling

+

THM44841E200AL
corpo luce lineare / linear light body
con 1 ghiera / with 1 fixing ring

+

THV448410150..
diffusore in vetro / glass diffuser d.23 cm

+

THV448420150..
diffusore in vetro / glass diffuser d.32 cm

THR44841E210NB
rosone / ceiling

+

THM44841E200AL
corpo luce lineare / linear light body
con 1 ghiera / with 1 fixing ring

+

2 x THV448410150..
diffusore in vetro / glass diffuser d.23

PAOLO RIZZATTO vive e lavora a Milano occupandosi di architettura, interni, design e didattica. Nel 1978 ha fondato, con Riccardo Sarfatti e Sandra Severi, la società Luceplan. I suoi lavori sono inclusi nelle collezioni permanenti di numerosi musei e fondazioni. Ha progettato e progetta per società italiane e straniere. Tra i riconoscimenti ricevuti: 5 Premi Compasso d'oro, 2 Good Design Award, 3 Red Dot Award Design Innovations, European Community Design Prize, Premio dei Premi per l'Innovazione, Prix Euroéen d'architecture Philipp Rotthier.

Paolo Rizzatto lives and works in Milan dealing with architecture, interiors, design and education. In 1978 he founded the company Luceplan with Riccardo Sarfatti and Sandra Severi. His works are included in the permanent collections of numerous museums and foundations. He has designed for Italian and foreign companies. Among the awards he has received: 5 Compasso d'oro Awards, 2 Good Design Awards, 3 Red Dot Award Design Innovations, European Community Design Prize, Prize of Prizes for Innovation, Prix Euroéen d'architecture Philipp Rotthier.





Francesco Librizzi_ Architect, born in 1977, in 2005 he founded the Francesco Librizzi Studio in Milan, a design atelier that develops projects in architecture, interiors, design and temporary installations. He realised projects for the Milan Triennale, the Italian Pavilion at the 12th Venice Architecture Biennale in 2010 and the Bahrain Pavilion for the 2012 Biennale. Among the awards he has received: the Prix Émile Hermès (2008), the Honourable Mention Compasso d'Oro (2014), "The AZ Awards 2015 Best Residential Interior", "Archmarathon Award 2015 "Private houses", the "German Design Award 2018 Best Exhibition Design". Since 2008, Francesco Librizzi has been teaching Interior and Exhibition Design at various universities and design academies. Since 2017, he has been Art Director of FontanaArte.

*FRANCESCO LIBRIZZI*_Architetto, classe 1977, nel 2005 fonda a Milano il Francesco Librizzi Studio, un atelier di progettazione che sviluppa progetti di architettura, interni, design e installazioni temporanee. Realizza progetti per la Triennale di Milano, per la Biennale di Venezia, Padiglione Italia alla XII Biennale di Architettura di Venezia del 2010 e il Padiglione del Bahrain per la Biennale del 2012. Tra i riconoscimenti ricevuti: il Prix Émile Hermès (2008), la Menzione d'onore Compasso d'Oro (2014), "L'AZ Awards 2015 Best Residential Interior", "Premio Archmarathon 2015 "Private houses", il "German Design Award 2018 Best Exhibition Design". Dal 2008, Francesco Librizzi insegna Interior ed Exhibition Design presso diversi istituti universitari e accademie di design. Dal 2017 è Art Director di FontanaArte.



Parley for the Oceans è un'organizzazione nonprofit fondata nel 2012 con l'obiettivo di proteggere gli oceani. Una rete ambientale globale dove creatori, pensatori e leader si riuniscono per aumentare la consapevolezza della bellezza e della fragilità degli oceani e collaborare a progetti che possono porre fine alla loro distruzione. Lavorando attraverso comunità creative, marchi, governi e gruppi ambientali, lavoriamo per proteggere l'ecosistema più grande e vitale della Terra, con un approccio guidato da creatività, collaborazione ed eco-innovazione.

Blom by Parley è una capsule collection di 3 speciali versioni colore ispirate al mondo marino e realizzate in plastica riciclata proveniente dagli oceani.

I colori sono turchese, avorio chiaro e salmone.

Founded in 2012, Parley for the Oceans is a nonprofit environmental organization that focuses on protection of Oceans. It is a network where creators, thinkers and leaders come together to raise awareness for the beauty and fragility of the oceans and collaborate on projects that can end their destruction. Working across the creative communities, brands, governments and environmental groups, we take action to protect the oceans, Earth's largest and most vital ecosystem, with an approach led by creativity, collaboration and eco-innovation.

The project is a capsule of BLOM collection of 3 color versions made in recycled Oceans plastic. These are the colors turquoise, light ivory and pink salmon.

Lampada da tavolo a luce diffusa regolabile tramite la rotazione dei petali sulla base. Montatura in alluminio verniciato, petali in materiale plastico riciclato (dagli oceani). Cavo di alimentazione, interruttore e spina trasparenti. Spina europea due poli. Fonte luminosa non inclusa.

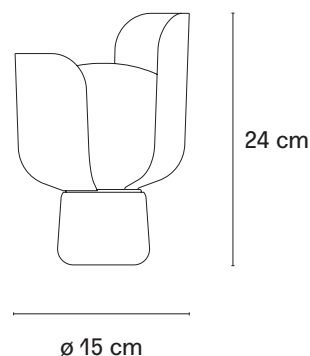





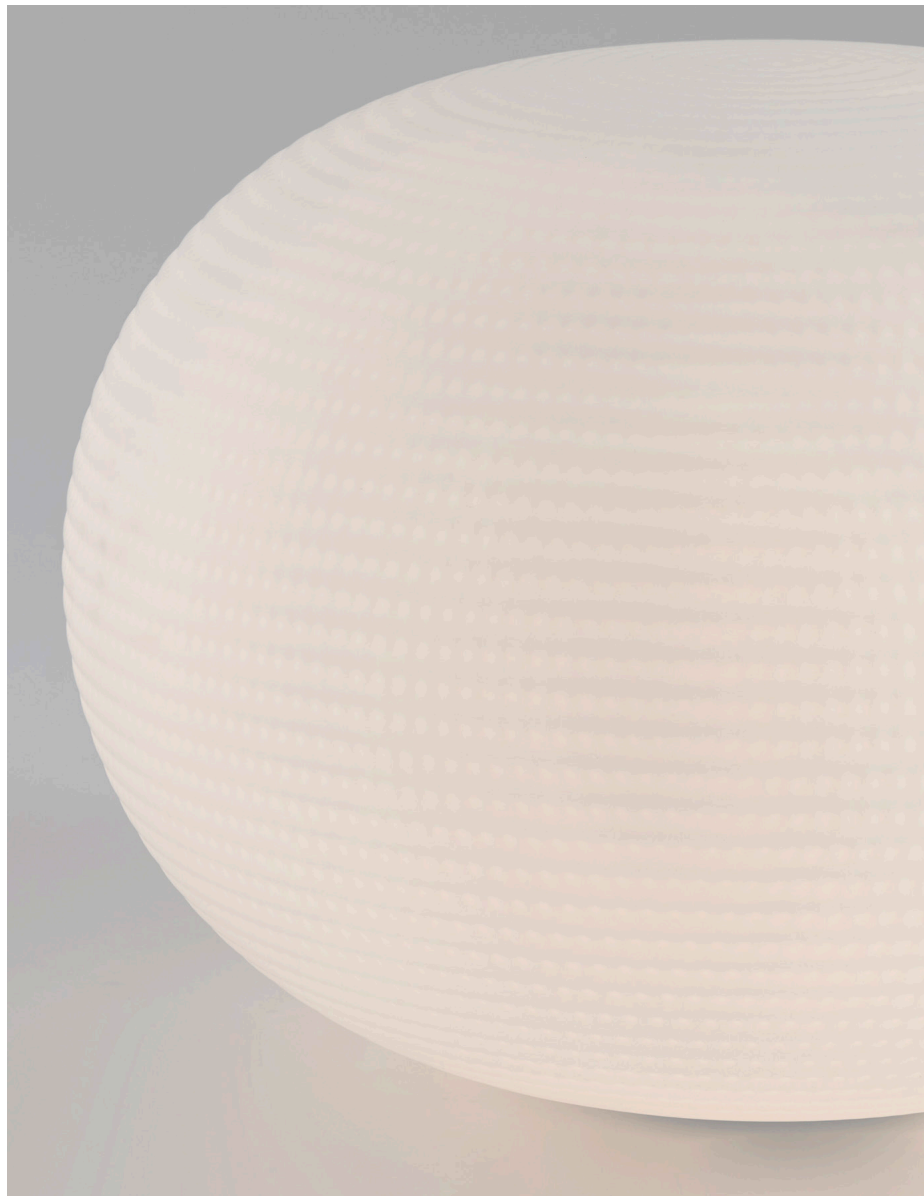

Table lamp with diffused light adjustable by moving the petals. Frame made of painted aluminium with petals made in recycled plastic (from oceans). Transparent power cable, plug and switch. European two-pole plug. Bulb not included.

Codice Code	F425305350TPNE
Materiale Material	Plastica riciclata, Alluminio Recycled plastic, Aluminum
Colore Color	 Turchese RAL6034 Torquoise
Sorgente luminosa Light source	1x max 11W E14
Dimmer incluso Dimmer included	No
 <small>Classe II</small>  IP20	
Codice Code	F425305350ACNE
Materiale Material	Plastica riciclata, Alluminio Recycled plastic, Aluminum
Colore Color	 Avorio chiaro RAL1015 Light ivory
Sorgente luminosa Light source	1x max 11W E14
Dimmer incluso Dimmer included	No
 <small>Classe II</small>  IP20	
Codice Code	F425305350RBNE
Materiale Material	Plastica riciclata, Alluminio Recycled plastic, Aluminum
Colore Color	 Salmone RAL3012 Salmon
Sorgente luminosa Light source	1x max 11W E14
Dimmer incluso Dimmer included	No
 <small>Classe II</small>  IP20	



BIANCA is a family of luminaires with the decoration on the diffuser surface features an orderly series of shallow delicate grooves etched into the white glass, yielding an effect resembling small footprints on fresh snow. Mouth blown, belt sanded and dipped in acid to obtain the distinctive 'silk effect' typical of fine glassware, Bianca diffusers are available in three different diameters to complete all thirteen types of luminaires belonging to the family. The largest diffuser has a 50 cm diameter and, owing to its dimensions and the amount of glass involved, continues to pose a considerable challenge even for the ablest of glassblowers trained in the fixed-mould blowing technique, which – according to the traditional Venetian production process – is performed without any external aids for turning and shaping the glass blob inside the mould, but relies solely on the glassblower's skill and lung capacity



BIANCA è una famiglia di apparecchi di illuminazione con la decorazione superficiale del diffusore che è caratterizzata da una serie ordinata di leggeri e delicati solchi che, sul bianco volume del vetro, ricordano delle piccole impronte sulla neve fresca. Soffiati a bocca, molati a nastro e poi passati nell'acido al fine di ottenere il caratteristico "effetto seta" dei vetri di pregio, i diffusori di Bianca sono disponibili in tre diametri che completano tutte le tredici tipologie di apparecchi che ne declinano la famiglia. Il più grande misura 50 cm di diametro e, per dimensioni e quantità di vetro, ha rappresentato, rappresenta e rappresenterà ad ogni produzione una autentica sfida anche per i più abili maestri vetrai, abituati a soffiare vetri a fermo che, secondo il tradizionale processo produttivo veneziano, non prevede l'aiuto di ausili esterni per far girare e modellare la massa di vetro nello stampo, ma solo l'impiego della propria maestria e capacità polmonare.



Lampada da tavolo a luce diffusa. Diffusore in vetro incamiciato di colore bianco latte, soffiato a fermo e satinato. Montatura in metallo verniciato. Cavo di alimentazione, spina e interruttore trasparenti. Spina europea due poli. Lampadina non inclusa.

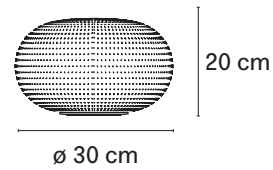
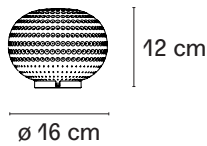

La collezione BIANCA si rinnova sostituendo la sorgente luminosa a LED con quella a lampadina. La versione piccola offre l'attacco G9, mentre per la media l'attacco E27 come per la misura grande.

Table lamp with diffused and not dimmable light. Milk-white diffuser made of blown glass with satin-finish. Painted metal frame. Transparent power cable, plug and switch. European two-pole plug. Bulb not included.



The Bianca collection gets a makeover by replacing the LED light source with a bulb light source. The small version offers the G9 socket, while for the medium size the E27 socket as for the large size.

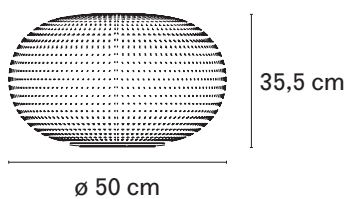

Codice Code	F430800150BINE
Materiale Material	Vetro, Metallo Glass, Metal
Colore Color	○ Bianco White
Sorgente luminosa Light source	1x max 30W G9
Dimmer incluso Dimmer included	No
  Classe II  IP20	

Codice Code	F430805150BINE
Materiale Material	Vetro, Metallo Glass, Metal
Colore Color	○ Bianco White
Sorgente luminosa Light source	1x max 46W E27
Dimmer incluso Dimmer included	Si Yes
  Classe II  IP20	



Codice Code	F430810150BINE
Materiale Material	Vetro, Metallo Glass, Metal
Colore Color	○ Bianco White
Sorgente luminosa Light source	1x max 116W E27
Dimmer incluso Dimmer included	Si Yes
  Classe II  IP20	



Lampada da parete e plafone a luce diffusa dimmerabile. Diffusore in vetro incamiciato di colore bianco latte,soffiato a fermo e satinato. Montatura in metallo verniciato. Lampadina non inclusa.

La collezione BIANCA si rinnova sostituendo la sorgente luminosa a LED con quella a lampadina. La versione piccola offre l'attacco G9, mentre per la media l'attacco E27 come per la misura grande.

Wall/ceiling lamp with diffused light. Milk-white diffuser made of blown glass with satin-finish. Painted metal frame. Bulb not included.

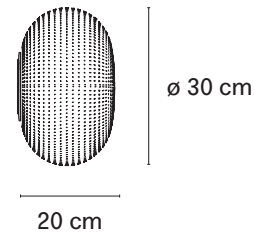
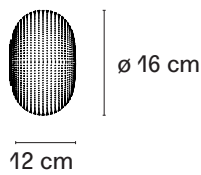

The Bianca collection gets a makeover by replacing the LED light source with a bulb light source. The small version offers the G9 socket, while for the medium size the E27 socket as for the large size.

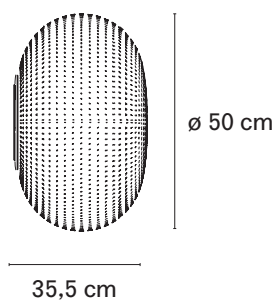

Codice Code	F432860150BINE
Materiale Material	Vetro, Metallo Glass, Metal
Colore Color	○ Bianco White
Sorgente luminosa Light source	1x max 30W G9
Dimmerabile Dimmable	Si Yes
  IP20	

Codice Code	F432865150BINE
Materiale Material	Vetro, Metallo Glass, Metal
Colore Color	○ Bianco White
Sorgente luminosa Light source	1x max 46W E27
Dimmerabile Dimmable	Si Yes
   IP20	



Codice Code	F432870150BINE
Materiale Material	Vetro, Metallo Glass, Metal
Colore Color	○ Bianco White
Sorgente luminosa Light source	1x max 116W E27
Dimmerabile Dimmable	Si Yes
   IP20	

Lampada a sospensione a luce diffusa dimmerabile. Diffusore in vetro incamiciato di colore bianco latte, soffiato a fermo e satinato. Cavo di alimentazione trasparente. Rosone in policarbonato verniciato. Lampadina non inclusa.

La collezione BIANCA si rinnova sostituendo la sorgente luminosa a LED con quella a lampadina. La versione piccola offre l'attacco G9, mentre per la media l'attacco E27 come per la misura grande.

Suspension lamp with diffused and dimmable light. Milk-white diffuser made of blown glass with satin-finish. Steel suspension cable. Transparent power cable. Painted polycarbonate ceiling rose. Bulb not included.

The Bianca collection gets a makeover by replacing the LED light source with a bulb light source. The small version offers the G9 socket, while for the medium size the E27 socket as for the large size.

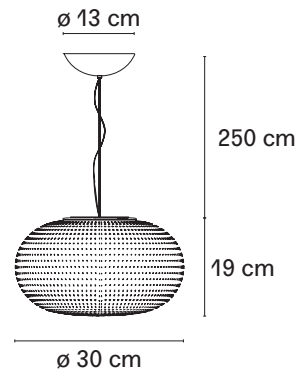
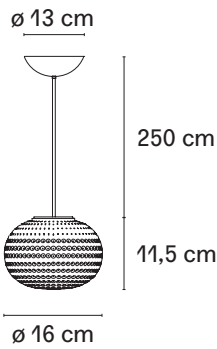

Codice Code	F430680150BINE
Materiale Material	Vetro, Metallo Glass, Metal
Colore Color	○ Bianco White
Sorgente luminosa Light source	1x max 30W G9
Dimmerabile Dimmable	Si Yes
	CE IP20

Codice Code	F430685150BINE
Materiale Material	Vetro, Metallo Glass, Metal
Colore Color	○ Bianco White
Sorgente luminosa Light source	1x max 46W E27
Dimmerabile Dimmable	Si Yes
	CE  IP20

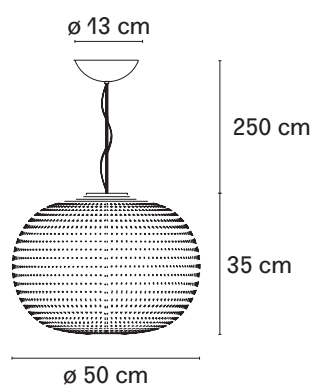

Codice Code	F430690150BINE
Materiale Material	Vetro, Metallo Glass, Metal
Colore Color	○ Bianco White
Sorgente luminosa Light source	1x max 116W E27
Dimmerabile Dimmable	Si Yes
 VETRO SOFFIATO BLOWN GLASS	CE IP20

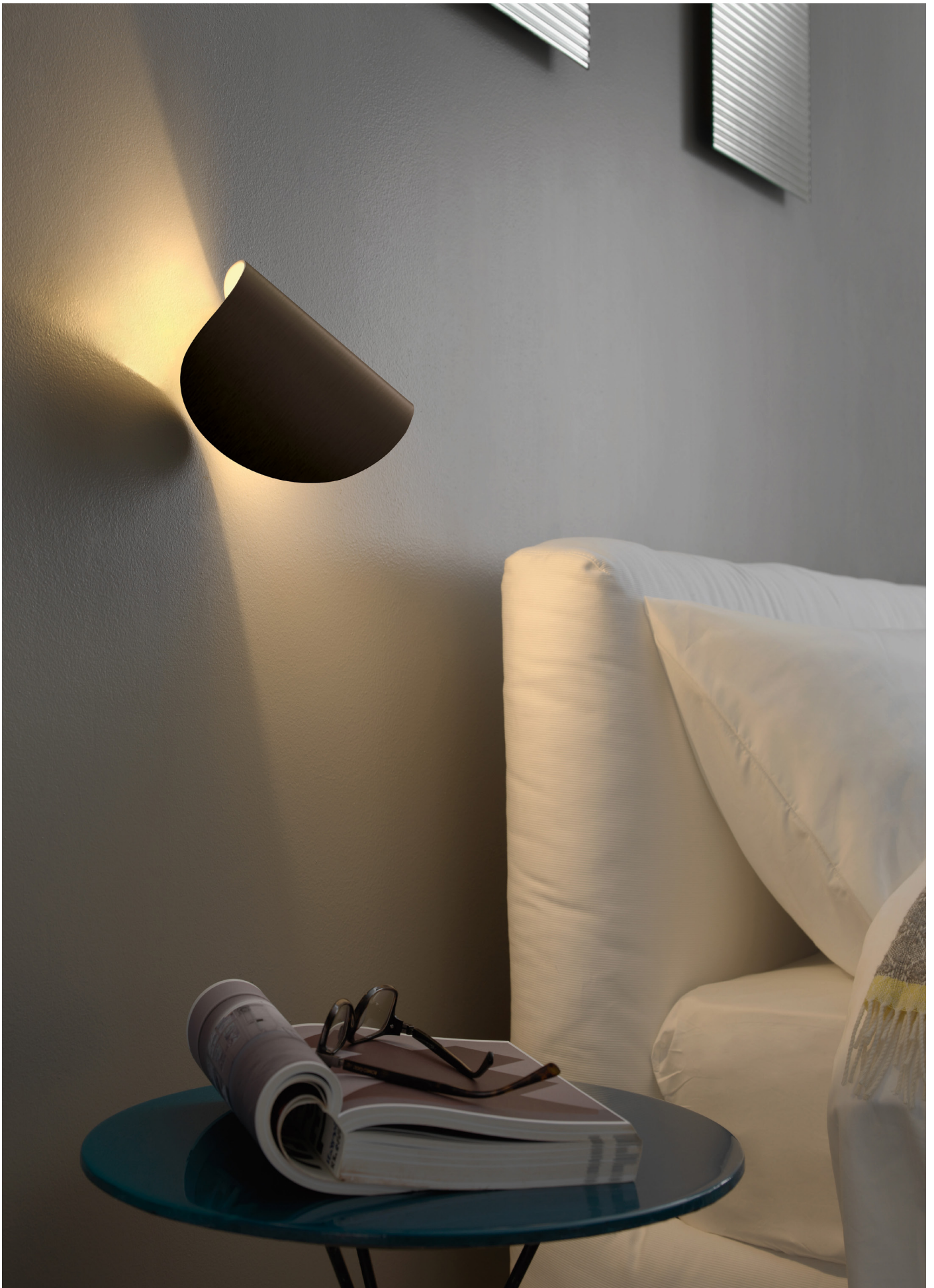

The wall lamp IO, designed in 2015 by the Swedes Marten Claesson, Eero Koivisto, and Ola Rune, is now presented with a new range expansion that includes new finishes and the possibility of infinite color customizations. The small curved lunar disk, serving as a diffuser, is now offered in Gold and Burnished versions, finishes that make this lamp even more precious.

Conceived with the aim of providing a highly personal and adjustable light, thanks to the double-axis rotation mount that allows the diffuser to rotate 360°, directing the light where needed, the IO lamp now allows for additional customizations: in fact, the white version is treated with a special paint that can be painted in any desired color. We can thus have a lamp in our favorite color or one that best suits the wall and surrounding decor.



IO, la lampada da parete disegnata nel 2015 dagli svedesi Marten Claesson, Eero Koivisto e Ola Rune, viene ora presentata con un nuovo ampliamento di gamma che prevede nuove finiture e la possibilità di infinite personalizzazioni di colore. Il piccolo disco lunare curvato, che funge da diffusore, viene ora proposto nelle versioni Oro e Brunito, finiture che rendono questa lampada ancora più preziosa.

Nata con lo scopo di fornire una luce il più possibile personale e modulabile, grazie alla montatura dal doppio asse di rotazione che consente al diffusore di ruotare di 360° gradi direzionando la luce laddove è necessario, la lampada IO permette ora ulteriori personalizzazioni: infatti, la versione bianca è trattata con una speciale vernice che può essere pitturata in qualsiasi colore si desideri. Potremo quindi avere una lampada nel nostro colore preferito o che più si adatta alla parete e all'arredo circostante.

Lampada da parete a luce direzionabile. Montatura in metallo verniciato. Grazie alla montatura dal doppio asse di rotazione, la lampada si muove sia sull'asse longitudinale sia lungo quello trasversale, consentendo una gestione totale della luce. Con un movimento Up/Down sul diffusore esterno è possibile inoltre aprire e chiudere il fascio luminoso. Led integrato.

L'ampliamento di gamma di IO prevede la dimmerabilità della luce mediante TRIAC.

Wall lamp with directional light. Painted metal frame. Thanks to its dual-axis rotation frame, it has the distinguishing feature rotating on both longitudinal and transverse axes, for total light management. The Up/Down movement on the external diffuser widens and narrows the ray of light. Integrated led.

The IO range expansion includes the dimmability of light through TRIAC.



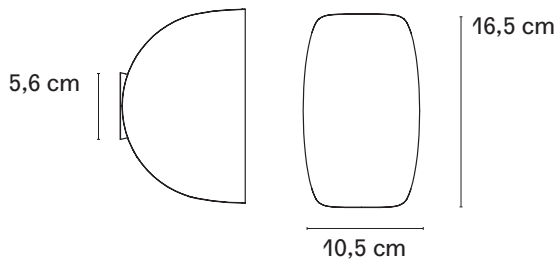

Codice Code	F449045200BVLE
Materiale Material	Metallo Metal
Colore Color	○ Bianco, Verniciabile White, Paintable
Sorgente luminosa Light source	LED 2x4,5W (2700K, CRI>90, 2x350Lm)
Dimmerabile Dimmable	Si, TRIAC Yes, TRIAC
Classe energetica Energy label	F



Codice Code	F449045200BLLE
Materiale Material	Metallo Metal
Colore Color	● Blu Blue
Sorgente luminosa Light source	LED 2x4,5W (2700K, CRI>90, 2x350Lm)
Dimmerabile Dimmable	Si, TRIAC Yes, TRIAC
Classe energetica Energy label	F



Codice Code	F449045200BSLE
Materiale Material	Metallo Metal
Colore Color	● Bronzo Bronze
Sorgente luminosa Light source	LED 2x4,5W (2700K, CRI>90, 2x350Lm)
Dimmerabile Dimmable	Si, TRIAC Yes, TRIAC
Classe energetica Energy label	F



Codice Code	F449045200GSLE
Materiale Material	Metallo Metal
Colore Color	● Grigio scuro Dark gray
Sorgente luminosa Light source	LED 2x4,5W (2700K, CRI>90, 2x350Lm)
Dimmerabile Dimmable	Si, TRIAC Yes, TRIAC
Classe energetica Energy label	F



Codice Code	F449045200OOLE
Materiale Material	Metallo Metal
Colore Color	● Oro Gold
Sorgente luminosa Light source	LED 2x4,5W (2700K, CRI>90, 2x350Lm)
Dimmerabile Dimmable	Si, TRIAC Yes, TRIAC
Classe energetica Energy label	F



Codice Code	F449045200ROLE
Materiale Material	Metallo Metal
Colore Color	● Rosso Red
Sorgente luminosa Light source	LED 2x4,5W (2700K, CRI>90, 2x350Lm)
Dimmerabile Dimmable	Si, TRIAC Yes, TRIAC
Classe energetica Energy label	F





When we speak of a “cameo” in a film or play, we mean the brief and discreet appearance of a famous character. In the same way, *CAMEO*, the new light by FontanaArte designed by Studio Claesson Koivisto Rune, is a lamp with character and personality, essential and fundamental in its function without being the star of the room. It is a lamp that can go unnoticed by the unobservant gaze of the person who observes the environment as a whole and does not dwell on the details.



Così come quando si parla di “cameo” in un film o opera teatrale, si intende la breve e discreta apparizione di un personaggio famoso, allo stesso modo *CAMEO*, nuova luce di FontanaArte disegnata dallo Studio Claesson Koivisto Rune, è una lampada di carattere e personalità, essenziale e fondamentale nella sua funzione pur senza essere la protagonista dell’ambiente.

Una lampada che può passare inosservata allo sguardo poco attento di colui che osserva l’ambiente nel suo complesso e non si sofferma sui particolari.

Lampada da tavolo ricaricabile, in vetro soffiato. Disponibile in due versioni: in vetro soffiato bianco lucido abbinato a una montatura in metallo cromato e in vetro soffiato satinato abbinato a una montatura in metallo verniciata in oro satinato. Il cerchio metallico decorativo, posizionato sul diffusore, è realizzato nello stesso materiale e finitura della base e riporta il logo FontanaArte serigrafato. Fonte luminosa LED integrata e dimmerabile. Un pulsante touch trasparente permette l'accensione, lo spegnimento e la regolazione dell'intensità della luce. La lampada è alimentata da una batteria della durata di 8 ore e ricaricabile mediante cavo con presa USB incluso nella confezione. Alimentatore su spina non incluso nella confezione. Uso interno/esterno.

Rechargeable table lamp, made of blown glass. Available in two versions: glossy white blown glass paired with a chrome metal frame, and satin-finished blown glass paired with a satin gold painted metal frame. The decorative metal ring, positioned on the diffuser, is made of the same material and finish as the base and features the serigraphed FontanaArte logo. Integrated and dimmable LED light source. A transparent touch button allows for turning the lamp on and off and adjusting the light intensity. The lamp is powered by a rechargeable battery with an 8-hour lifespan, rechargeable via the included USB cable. Wall plug adapter not included in the package. Suitable for indoor and outdoor use.



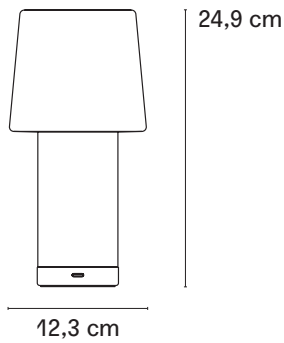

Codice Code	F448005550CRBW
Materiale Material	Vetro, Metallo Galvanizzato Glass, Galvanized Metal
Colore Color	☉ Bianco lucido, Cromo Glossy white, Chrome
Sorgente luminosa Light source	LED 2x0,7W (2700K, CRI>80, 220Lm)
Dimmer incluso Dimmer included	Si, touch Yes, touch
Classe energetica Energy label	F
 VETRO SOFFIATO BLOWN GLASS	CE IP54

Codice Code	F448005160OOBW
Materiale Material	Vetro, Metallo Verniciato Glass, Painted Metal
Colore Color	☉ Bianco satinato, Oro Satin white, Gold
Sorgente luminosa Light source	LED 2x0,7W (2700K, CRI>80, 220Lm)
Dimmer incluso Dimmer included	Si, touch Yes, touch
Classe energetica Energy label	F
 VETRO SOFFIATO BLOWN GLASS	CE IP54

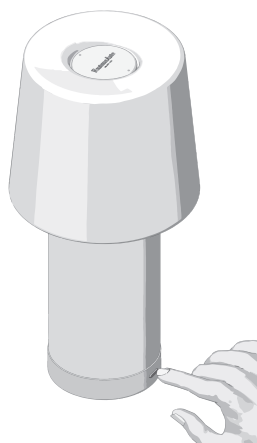

Pulsante touch trasparente permette l'accensione, lo spegnimento e la regolazione dell'intensità della luce.

A transparent touch button allows switching on and off and adjusting the light intensity as well as indicating the charge level.

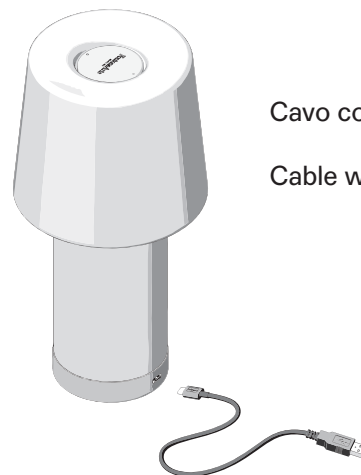

Cavo con presa USB

Cable with USB socket.



Lo studio di architettura svedese Claesson Koivisto Rune è stato fondato nel 1995 da Mårten Claesson, Eero Koivisto e Ola Rune. Oggi è uno studio di fama internazionale, che si occupa sia di architettura che di design. Primo studio svedese ad esporre nella sezione internazionale della Biennale di Architettura di Venezia nel 2004, è anche responsabile di progetti premiati come l'hotel K5 e l'edificio polivalente a Tokyo; Hotel De Bergenske: Grand Hotel Terminus, Bergen Børs, Villa Terminus e Hotel Zander K, tutti a Bergen, Norvegia; Collezione di case prefabbricate Tind per Fiskarhedenvillan, galleria d'arte Inde/Jacobs a Marfa, Texas, villa privata Widlund House a Öland, edificio Örsta Gallery a Kumla, casa della cultura Sfera Building a Kyoto e Nobis Hotel a Stoccolma.

The Swedish architecture studio Claesson Koivisto Rune was founded in 1995 by Mårten Claesson, Eero Koivisto and Ola Rune. Today an internationally renowned reality, it deals with both architecture and design. The first Swedish studio to exhibit in the international section of the Venice Architecture Biennale in 2004, they are also responsible for award-winning projects such as the Bergen Børs hotels, Villa Terminus & Hotel Zander K, all in Bergen, Norway; Tind Prefab house collection for Fiskarhedenvillan, Inde/Jacobs art gallery in Marfa, Texas, Widlund House private villa in Öland, Örsta Gallery building in Kumla, Sfera Building culture house in Kyoto and Nobis Hotel in Stockholm. Claesson Koivisto Rune received the German Design Award (Gold and Silver) 2011, Designer of the Year 2011 and Furniture of the Year 2012 from Elle Deco (Sweden), both Designer of the Year and Best Seating 2014 from Elle Décor Italia, and the Red Dot Design Award - Best of the Best 2014, becoming the first office to hold a Red Dot in five different product categories. Their work is exhibited in the permanent collection of the Swedish National Museum. They collaborate with some of the most prestigious and renowned design companies for which they have signed lighting and furniture projects sold all over the world.





Una forma naturale che da sempre è simbolo di perfezione, in cui convivono armonicamente simmetria e asimmetria. Disegnato nel 1972, il guscio contiene una fonte luminosa: un'idea ironica che ancora oggi conquista. Come in natura, anche nella lampada *UOVO* il guscio è esempio assoluto di leggerezza: una forma elegante in vetro soffiato bianco satinato, che diffonde uniformemente una luce calda e avvolgente.

A natural form and timeless symbol of perfection, in which symmetry and asymmetry harmoniously coexist. Designed in 1972, the 'shell' of the egg contained a light source: an ironic idea that still works today. As in nature, the shell of the *UOVO* lamp is the embodiment of absolute lightness, an elegant form in white satin blown glass that gives off a warm, uniform light.



Lampada da tavolo ricaricabile, in vetro soffiato satinato. Fonte luminosa LED integrato e dimmerabile – Un pulsante touch trasparente permette l'accensione, lo spegnimento e la regolazione dell'intensità della luce. La lampada è alimentata da una batteria della durata di 8 ore e ricaricabile mediante cavo con presa USB incluso nella confezione. Alimentatore su spina non incluso nella confezione. Uso interno/esterno.

rechargeable table lamp, made of blown glass. Integrated and dimmable LED light source – A transparent touch button allows for turning the lamp on and off and adjusting the light intensity. The lamp is powered by a rechargeable battery with an 8-hour lifespan, rechargeable via the included USB cable. Wall plug adapter not included in the package. Suitable for indoor and outdoor use.

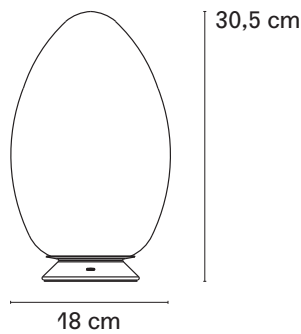

Codice Code	F264600150BIBW
Materiale Material	Vetro, Metallo Glass, Metal
Colore Color	○ Bianco White
Sorgente luminosa Light source	LED 2,2W (2700K, CRI>80,250Lm)
Dimmer incluso Dimmer included	Si, touch Yes, touch
Classe energetica Energy label	F
 VETRO SOFFIATO BLOWN GLASS	CE IP54

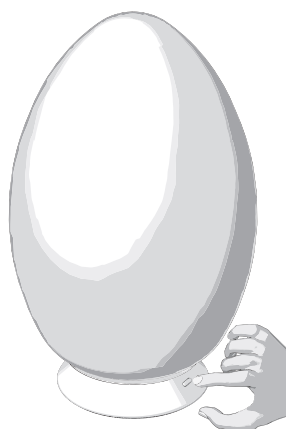

Pulsante touch trasparente permette l'accensione, lo spegnimento e la regolazione dell'intensità della luce.

A transparent touch button allows switching on and off and adjusting the light intensity as well as indicating the charge level.



Cavo con presa USB
Cable with USB socket.

Lampada a sospensione a luce diffusa dimmerabile. Diffusore in vetro soffiato bianco satinato. Supporto diffusore in metallo. Cavo di alimentazione trasparente. Rosone in policarbonato verniciato. Fonte luminosa non inclusa nella confezione.

Suspension lamp with diffused and dimmable light. Diffuser made of blown glass with satin-finish. Transparent power cable. Painted polycarbonate ceiling rose. Bulb not included.

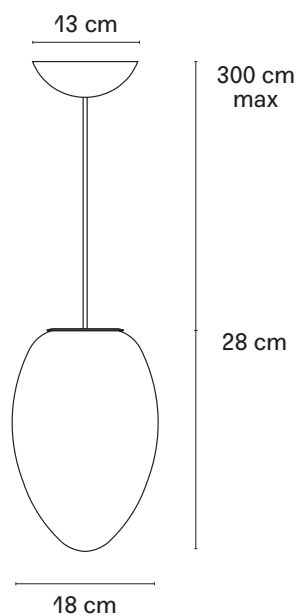

Codice Code	F264680100BINE
Materiale Material	Vetro Glass
Colore Color	○ Bianco White
Sorgente luminosa Light source	1 x max 30W E27
Dimmerabile Dimmable	Si Yes
	CE IP20

Ben Swildens, nato nel 1938, è un designer di origine olandese. Costretto a cambiare paese sin da piccolo a causa della professione del padre, architetto, lo segue in particolare in Marocco dove, alla scuola americana di Tangeri, imparerà l'arabo e lo spagnolo, imitando il padre attraverso il disegno. Dopo un passaggio al Politecnico in Svizzera, Ben Swildens si iscrive all'Ecole Supérieure des Arts Décoratifs di Parigi dove si diplomerà nel 1961. Inizia a lavorare per i suoi professori, grandi artigiani creativi dell'epoca, ma anche per aziende private. A partire dal 1962 e fino al 1969, collabora con il maestro vetraio e decoratore francese Max Ingrand, a numerosi progetti come la sede sociale di EDF o Peugeot, l'aeroporto di Lima, il Parlamento di Beirut o ancora il Musée de Genève. Lo stesso Max Ingrand spingerà Ben Swildens a occuparsi di industrial design.

Ben Swildens, born in 1938, is a Dutch designer who spent his childhood traveling from country to country with his father, an architect. In Morocco, at the American school in Tangiers, he learned Arabic and Spanish, and discovered drawing by imitating his father. After a period at the Polytechnic in Switzerland, Ben Swildens enrolled at the Ecole Supérieure des Arts Décoratifs in Paris, where he took his diploma in 1961. He began his career working for his professors, great creative artisans of the time, as well as for private companies. From 1962 to 1969, he collaborated with French master glassmaker and decorator Max Ingrand on numerous projects such as the headquarters of EDF and Peugeot, Lima airport, the Parliament building in Beirut and the Musée de Genève. Mas Ingrand would inspire Ben to go into industrial design. With his brother-in-law Bernard Cohen – future founder of the Parisian boutique Merci – Swildens launched Point, the company that produces and sells the furniture he designs.

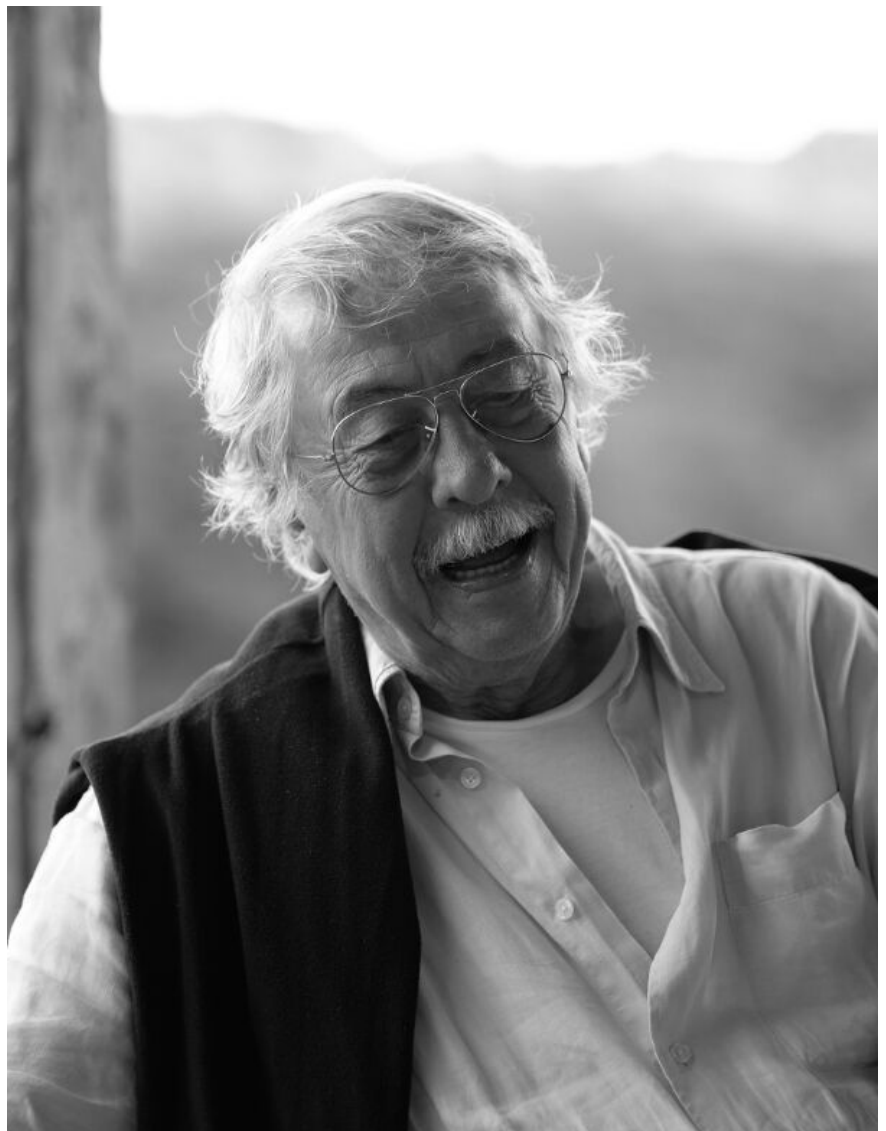

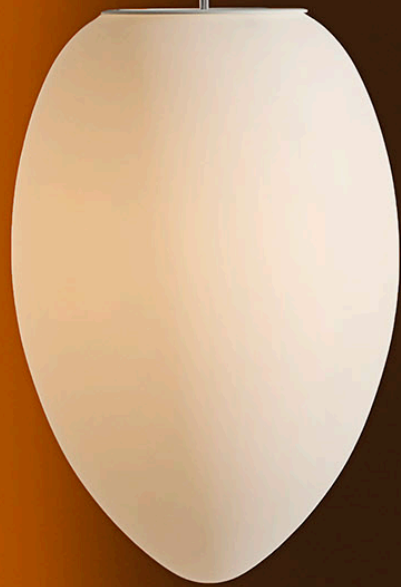



Due materiali: metallo e vetro, come nella storica tradizione di FontanaArte. Il metallo funge da base e contiene la sorgente luminosa mentre il vetro, vero protagonista del progetto, viene sapientemente lavorato da abili artigiani in un processo di fusione fra una porzione di vetro trasparente ed una satinata dalla quale la luce si diffonde. *FONTANELLA* è formata dall'unione di due vetri: il tubo interno viene filettato, sabbiato ed infine giuntato con il vetro soffiato a forma di bolla. Ciò che rende particolarmente raffinata la lavorazione è la giuntura manuale delle due parti che richiede la sapiente tecnica di un artigiano. Il vetro inoltre, da sempre il materiale per eccellenza dei prodotti FontanaArte, è il più cristallino esistente sul mercato. A completare la contemporaneità di questo pezzo FontanaArte, si aggiunge la possibilità di utilizzare lampadine, dimmerabili e non, a massimo risparmio energetico.

Two materials: metal and glass, as in the historic tradition of FontanaArte. The metal acts as a base and contains the light source while the glass, the true protagonist of the project, is expertly worked by skilled craftsmen in a process of fusion between a portion of transparent glass and a satin one from which the light diffuses. *FONTANELLA* is formed by the union of two glasses: the internal tube is threaded, sandblasted and finally joined with the bubble-shaped blown glass. What makes the processing particularly refined is the manual joining of the two parts, which requires the skillful technique of a craftsman. Furthermore, the glass, which has always been the material par excellence of the FontanaArte product, is the most crystalline on the market. The use of light bulbs, dimmable and not dimmable, for the biggest energy saving, complete the contemporaneity of this FontanaArte piece.

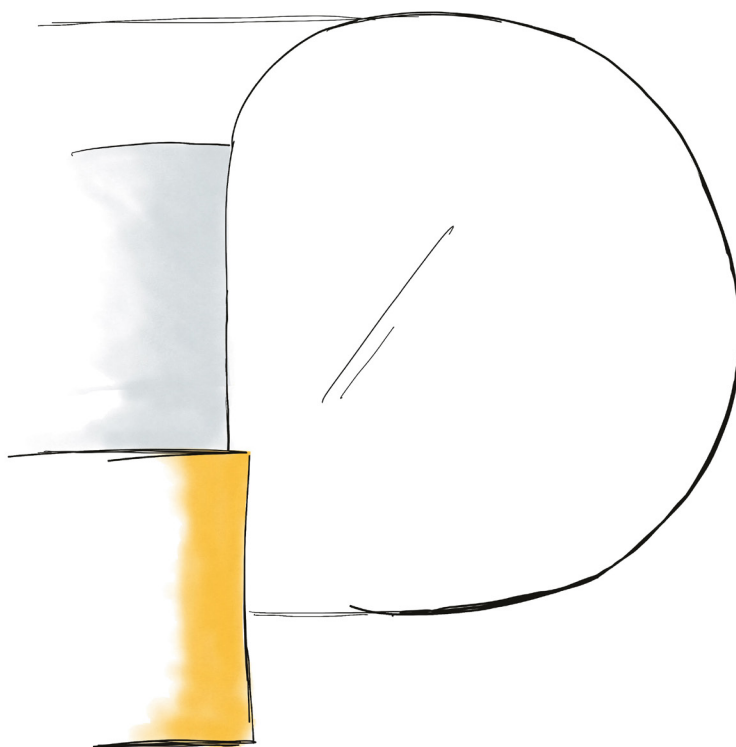





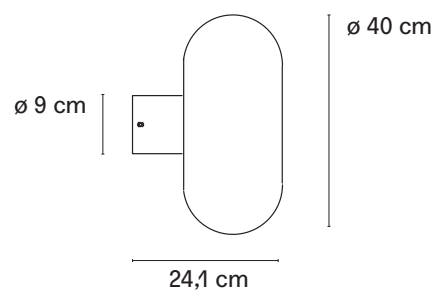
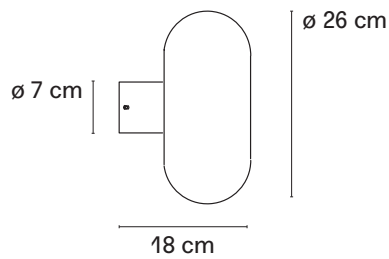

Lampada da parete e plafone a luce diffusa dimmerabile. Montatura in metallo galvanizzato, disponibile in due dimensioni e in 3 varianti colore: oro, cromo e nero. Diffusore in vetro soffiato in borosilicato. Fonte luminosa non inclusa.



Wall and ceiling lamp with dimmable diffused light. Galvanized metal frame, available in two sizes and in 3 color variants: gold, chrome, and black. Blown borosilicate glass diffuser. Light source not included.













Codice Code	F447745550CRNE
Materiale Material	Vetro, Metallo Galvanizzato Glass, Galvanized Metal
Colore Color	 Cromo Chrome
Sorgente luminosa Light source	1x max 28W E14
Dimmerabile Dimmable	Si Yes
 VETRO SOFFIATO BLOWN GLASS	 IP20

Codice Code	F447750550CRNE
Materiale Material	Vetro, Metallo Galvanizzato Glass, Galvanized Metal
Colore Color	 Cromo Chrome
Sorgente luminosa Light source	1x max 77W E27
Dimmerabile Dimmable	Si Yes
 VETRO SOFFIATO BLOWN GLASS	 IP20

Codice Code	F447745550NENE
Materiale Material	Vetro, Metallo Galvanizzato Glass, Galvanized Metal
Colore Color	 Nero lucido Glossy black
Sorgente luminosa Light source	1x max 28W E14
Dimmerabile Dimmable	Si Yes
 VETRO SOFFIATO BLOWN GLASS	 IP20

Codice Code	F447750550NENE
Materiale Material	Vetro, Metallo Galvanizzato Glass, Galvanized Metal
Colore Color	 Nero lucido Glossy black
Sorgente luminosa Light source	1x max 77W E27
Dimmerabile Dimmable	Si Yes
 VETRO SOFFIATO BLOWN GLASS	 IP20

Codice Code	F447745550OTNE
Materiale Material	Vetro, Metallo Galvanizzato Glass, Galvanized Metal
Colore Color	 Ottone lucido Glossy brass
Sorgente luminosa Light source	1x max 28W E14
Dimmerabile Dimmable	Si Yes
 VETRO SOFFIATO BLOWN GLASS	 IP20



Codice Code	F447750550OTNE
Materiale Material	Vetro, Metallo Galvanizzato Glass, Galvanized Metal
Colore Color	 Ottone lucido Glossy brass
Sorgente luminosa Light source	1x max 77W E27
Dimmerabile Dimmable	Si Yes
 VETRO SOFFIATO BLOWN GLASS	 IP20



Lampada sospensione a luce diffusa dimmerabile. Montatura in metallo galvanizzato, disponibile in due dimensioni e in 3 varianti colore: oro, cromo e nero. Diffusore in vetro soffiato in borosilicato. Cavo di sospensione in acciaio. Cavo di alimentazione trasparente. Rosone in metallo. Fonte luminosa non inclusa.

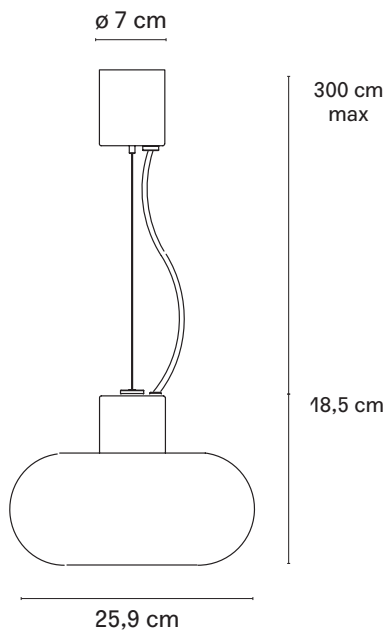

Dimmable suspended pendant lamp with diffused light. Galvanized metal frame, available in two sizes and in 3 color variants: gold, chrome, and black. Blown borosilicate glass diffuser. Steel suspension cable. Transparent power cable. Metal ceiling rose. Light source not included.









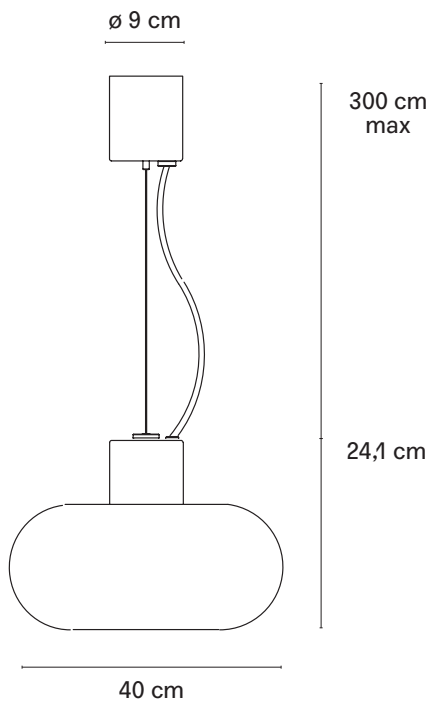

Codice Code	F447885550CRNE
Materiale Material	Vetro, Metallo Galvanizzato Glass, Galvanized Metal
Colore Color	 Cromo Chrome
Sorgente luminosa Light source	1x max 28W E14
Dimmerabile Dimmable	Si Yes
 VETRO SOFFIATO BLOWN GLASS	 IP20



Codice Code	F447885550NENE
Materiale Material	Vetro, Metallo Galvanizzato Glass, Galvanized Metal
Colore Color	 Nero lucido Glossy black
Sorgente luminosa Light source	1x max 28W E14
Dimmerabile Dimmable	Si Yes
 VETRO SOFFIATO BLOWN GLASS	 IP20

Codice Code	F447885550OTNE
Materiale Material	Vetro, Metallo Galvanizzato Glass, Galvanized Metal
Colore Color	 Ottone lucido Glossy brass
Sorgente luminosa Light source	1x max 28W E14
Dimmerabile Dimmable	Si Yes
 VETRO SOFFIATO BLOWN GLASS	 IP20



Codice Code	F447890550CRNE
Materiale Material	Vetro, Metallo Galvanizzato Glass, Galvanized Metal
Colore Color	 Cromo Chrome
Sorgente luminosa Light source	1x max 77W E27
Dimmerabile Dimmable	Si Yes
 VETRO SOFFIATO BLOWN GLASS	 IP20

Codice Code	F447890550NENE
Materiale Material	Vetro, Metallo Galvanizzato Glass, Galvanized Metal
Colore Color	 Nero lucido Glossy black
Sorgente luminosa Light source	1x max 77W E27
Dimmerabile Dimmable	Si Yes
 VETRO SOFFIATO BLOWN GLASS	 IP20

Codice Code	F447890550OTNE
Materiale Material	Vetro, Metallo Galvanizzato Glass, Galvanized Metal
Colore Color	 Ottone lucido Glossy brass
Sorgente luminosa Light source	1x max 77W E27
Dimmerabile Dimmable	Si Yes
 VETRO SOFFIATO BLOWN GLASS	 IP20

Federico Peri nasce nel 1983 a Montebelluna in provincia di Treviso. Terminati gli studi universitari a Milano presso la facoltà di interior design dell'Istituto Europeo di Design, si trasferisce a Parigi grazie ad una borsa di studio di residenza per artisti. In questo periodo, ricco di contaminazioni internazionali e stimoli progettuali, inizia il proprio percorso professionale appassionandosi ai grandi maestri e definendo il proprio interesse come sinergia tra storico e contemporaneo. Rientra a Milano per lavorare presso Vudafieri Saverino Partners fino al 2011, quando avvia il proprio studio occupandosi prevalentemente di progettazione d'interni e arredo. Collabora con aziende, marchi di moda, professionisti e privati concependo progetti che siano strettamente connessi alle singole identità. E' tra i candidati come 'Migliore nuovo designer' del Salone del Mobile Milano 2017 con il prodotto "Galerie" progettato per FontanaArte, nominato per il Rising Talent Awards all'edizione di Maison&Object 2018 e tra i designer '7 per il futuro' selezionati da AD Italia nel 2018.

Federico Peri was born in 1983 in the province of Treviso. After completing his university degree in Milan at the faculty of interior design of the European Institute of Design, he moved to Paris on an artist residency grant. During this period, rich in international cross-contaminations and design stimuli, he began his professional career with a passion for the great masters and defined his personal interest as a synergy between the historical and the contemporary. He started his own studio in Milan in 2011 dealing with interior design, installations and product design. He collaborates with companies, fashion brands, professionals and private individuals conceiving projects that are closely related to individual identities. Among the candidates as 'Best new designer' at the Salone del Mobile Milano awards 2017 with the product "Galerie" designed for FontanaArte, nominated for Rising Talent Awards at the edition of Maison&Object 2018 and among the designers '7 for the future' selected by AD Italy in 2018.





LUNAIRE è una lampada da parete e plafone che stupisce per il suo effetto luminoso che ricorda il fenomeno di luce prodotto dalle eclissi. Un grande riflettore in alluminio dalla forma concava ospita al suo interno un disco frontale più piccolo; quest'ultimo, che alloggia al suo interno la fonte luminosa. Lunaire è una lampada adatta all'illuminazione di grandi spazi, siano essi domestici o in ambito contract.

LUNAIRE is a wall and ceiling lamp with a surprising light effect, reminiscent of the phenomenon produced by eclipses. A smaller front disc containing the light source is set inside a large concave aluminium diffuser. Lunaire is the perfect lighting solution areas, they residential or contract.

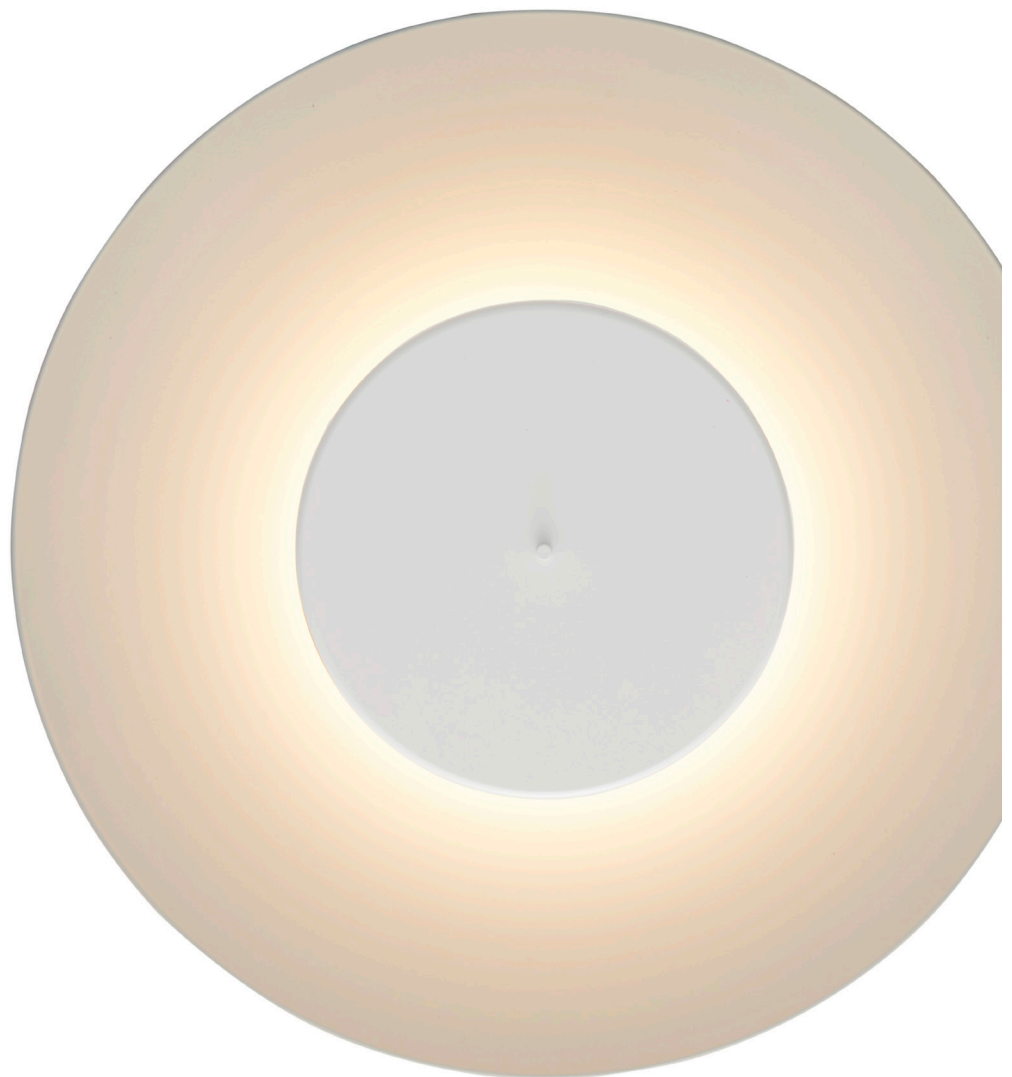

Lampada da parete/plafone a luce diffusa.
Corpo posteriore in metacrilato, riflettore
e tappo fisso in metallo verniciato bianco.
Led integrato.

Wall/ceiling lamp with diffused light.
Rear body made of acrylic glass,
reflector, and fixed front disc in white
painted metal. Integrated LED.

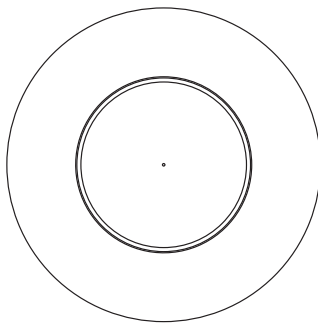

ø 50 cm

Codice Code	F424660350BILE
Materiale Material	Polimero, Metallo Verniciato Polymer, Painted Metal
Colore Color	○ Bianco White
Sorgente luminosa Light source	LED 10W (2700K, CRI 80, 1250Lm)
Dimmerabile Dimmable	Si, TRIAC Yes, TRIAC
Classe energetica Energy label	F

CE IP20

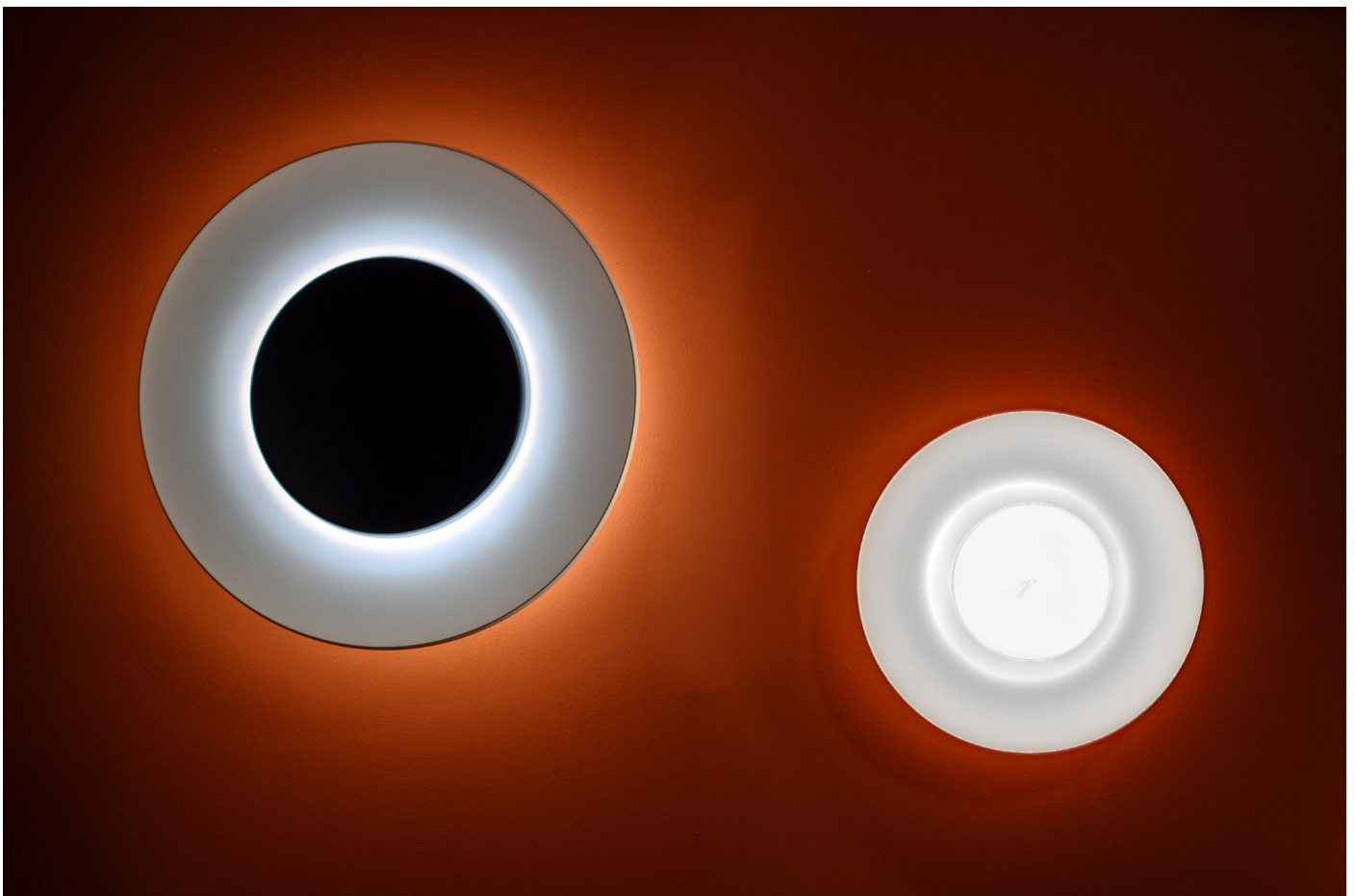

Ferréol Babin nasce nel 1987 a Digione, in Francia. Dopo la prima laurea in Space Design all'ENSA di Digione, si trasferisce in Giappone, presso la Nagoya University of Art & Design. Si rende conto che architettura e spazio non lo rappresentano per dimensione espressiva e decide di concentrarsi sugli oggetti. Successivamente lavora come stagista presso lo Studio Robert Stadler di Parigi. Nel 2012 si laurea all'ESAD di Reims, in Object Design. Ben presto la luce è apparsa come il suo materiale preferito con cui lavorare, grazie alla sua capacità di essere legata sia a un oggetto che allo spazio che lo circonda.

Ferréol Babin was born in 1987 in Dijon, France. After his first degree in Space Design at ENSA in Dijon, he moved to Japan, at Nagoya University of Art & Design. He realizes that architecture and space do not represent him in terms of expressive dimension and decides to focus on objects. He later worked as an intern at the Robert Stadler Studio in Paris. In 2012 he graduated from ESAD in Reims, in Object Design. Soon light appeared as his favourite material to work with, thanks to its ability to be linked both to an object and to the space around it.





NASKA, nata nel 1933 ed oggi fra le lampade di design più iconiche della storia, diventa grande. Archetipo della lampada da lavoro è oggi un must have negli studi professionali e atelier di artisti, lampada da scrivania per eccellenza, originale capostipite di tutte le lampade da tavolo con braccio bilanciato a molle. Nel 2023, in occasione del suo 90° compleanno, la famiglia si arricchisce di un nuovo inaspettato componente: il modello XL, una versione appunto extra large adatta anche per ambienti esterni. Oggetto senza tempo che, più di ogni altro, ha saputo esprimere una forte identità attraverso la sua forma archetipale, Naska XL è la lampada da esterno di design per esaltare la bellezza di giardino o terrazzi e permetterci di vivere gli spazi esteni in qualsiasi momento della giornata. La nuova versione XL di *NASKA* è disponibile nella versione indoor e outdoor, realizzata in metallo verniciato nelle colorazioni bianco e nero.



The *NASKA* family of lamps is a classic from 1933. Simple and functional, with a revolving, adjustable arm, it is available in three different versions – table, floor and wall. More than any other lamp, Naska expresses an unmistakable identity through its archetypal form. It is the desk lamp par excellence, the original ancestor of every lamp with a spring-balanced arm. A timeless object, suitable for both domestic spaces and those dedicated to work. The new XL version of *NASKA* is available in indoor and outdoor versions, made of painted metal in black and white.

Lampada da terra XL a luce diretta. Base e corpo in metallo verniciato bianco o nero. Cavo, dimmer e spina neri. Nella versione da esterno la spina non è inclusa. Lampadina non inclusa. Disponibile sia da esterno che interno.

XL floor lamp with direct light. Frame and body made of painted in black or white metal. Black power cable, dimmer and plug. In the outdoor version the plug is not included. Bulb not included. Available in outdoor and indoor version.

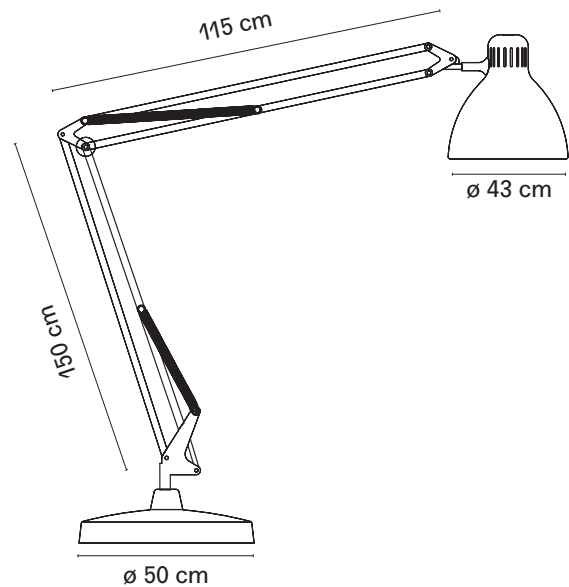
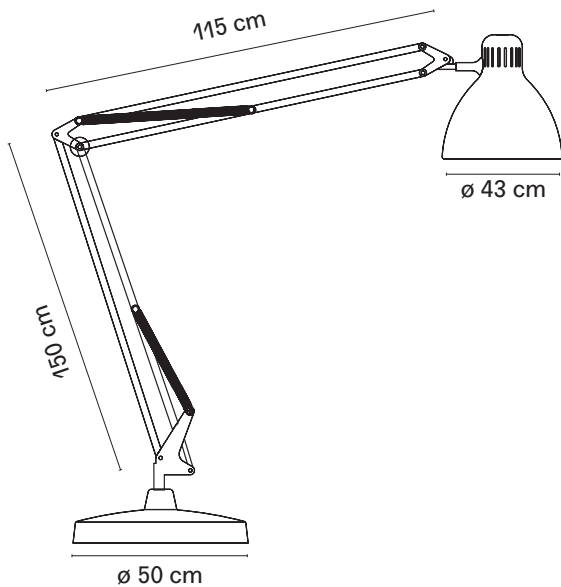

Codice Code	F810525200BINE
Materiale Material	Metallo Verniciato Painted Metal
Colore Color	○ Bianco White
Sorgente luminosa Light source	1x max 42W E27
Dimmer incluso Dimmer included	Si Yes

Codice Code	F810528200BINE
Materiale Material	Metallo Verniciato Painted Metal
Colore Color	○ Bianco White
Sorgente luminosa Light source	1x max 42W E27
Dimmer incluso Dimmer included	No

Codice Code	F810525200NENE
Materiale Material	Metallo Verniciato Painted Metal
Colore Color	● Nero Black
Sorgente luminosa Light source	1x max 42W E27
Dimmer incluso Dimmer included	Si Yes

Codice Code	F810528200NENE
Materiale Material	Metallo Verniciato Painted Metal
Colore Color	● Nero Black
Sorgente luminosa Light source	1x max 42W E27
Dimmer incluso Dimmer included	No

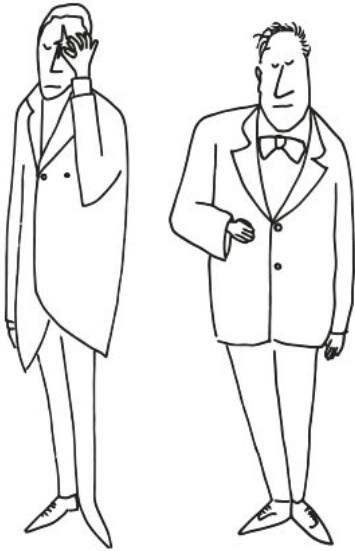

L'ARCHIVIO STORICO di FontanaArte è un patrimonio di idee, di schizzi su carta, di progetti, che in un primo momento vengono solo abbozzati all'interno dell'azienda e poi perfezionati nel corso degli anni, fino a manifestare tutto il loro potenziale, diventando parte della collezione FontanaArte. I progetti che nascono dall'archivio storico non si legano al nome di un solo designer, ma sono frutto di un lavoro in team, di tutte le energie creative dei professionisti che lavorano in azienda.

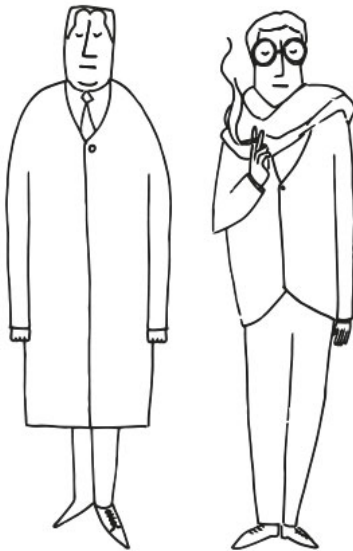

The *FONTANAARTE ARCHIVES* stand as a collection of ideas, of sketches on paper and designs, which are initially just drafted in-house and then developed over the years until they have reached their full potential, to become part of the FontanaArte collection. The designs that derive from the archives are not associated with the name of one designer alone, but are the fruit of team work, of the collective creative energy of the professionals that work in the company.



Vaso artistico soffiato a bocca che si ispira all'iconica abat-jour di FontanaArte, modello 1853 disegnato da Max Ingrand nel 1954, di cui è la fedele miniatura. *FONTANA* è un prezioso oggetto in vetro acidato bianco latte, che decora l'ambiente con elegante semplicità ed è indicato come inedito portafiori, per creare un'atmosfera intima come portacandela tealight o celare un profumatore di ambienti. Presentato in una elegante confezione, Fontana Vase è il regalo perfetto in ogni occasione: un riferimento di pregio per gli amanti del design.

An artistic hand-blown glass vase inspired by the iconic FontanaArte abat-jour, model 1853 designed by Max Ingrand in 1954, of which it is a faithful miniature replica. *FONTANA* is a precious object in milky white frosted glass that decorates the space with elegant simplicity and is suitable as a unique flower vase, for creating an intimate atmosphere as a tealight candle holder or concealing an air freshener. Presented in an elegant package, Fontana Vase is the perfect gift for any occasion: a prestigious reference for design enthusiasts.

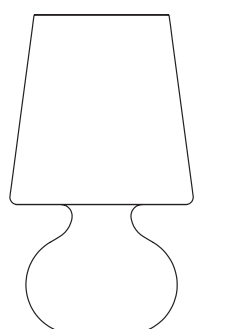

18,2 cm

ø 10,5 cm

Codice Code	F1800VA100BO00
Materiale Material	Vetro Glass
Colore Color	○ Bianco White

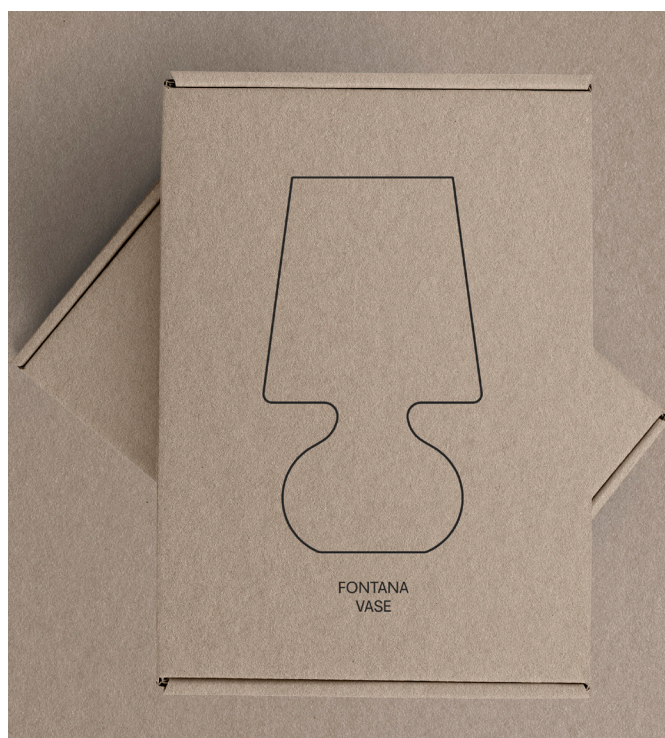







La lampada *FRENESI* nasce dalla passione dell'autore – il cineasta Luca Guadagnino – per l'art déco, stile amato in tutte le sue declinazioni, in particolare per l'angolarità, per il disegno, le forme regolari delle linee che si incontrano e incrociano. La collezione FontanaArte è tutt'oggi una sintesi di art déco che, in chiave italiana, illumina le case in tutto il mondo. L'autore si è interrogato sulla forma alla quale tendere per creare un oggetto che rispettasse l'espressione stilistica dell'epoca a cui si ispira ma con un linguaggio contemporaneo.

The *FRENESI* lamp comes from the author's passion – filmmaker Luca Guadagnino – for art deco, a style he loves in all its declinations, particularly for the angularity, the design, the regular shapes of the lines that meet and intersect. Today, the FontanaArte collection is still a synthesis of art deco, which, in an Italian key, illuminates homes all over the world. The designer questioned the form to which he should strive in order to create an object that respected the stylistic expression of the era from which it was inspired but with a contemporary language.



Nasce così Frenesi, dal nome della protagonista del romanzo *Vineland* dello scrittore statunitense Thomas Pynchon, ispirata all'idea dell'onda, una sensuale increspatura, realizzata nel materiale più puro e sostenibile come il vetro, che emana una luce morbida all'interno della struttura angolare.

This is how Frenesi was born, named after the protagonist of the novel *Vineland* by the American writer Thomas Pynchon, inspired by the idea of the wave, a sensual ripple, made of the purest and most sustainable material such as glass, which emanates a soft light within the angular structure.



Lampada da parete a luce diffusa dimmerabile. Diffusore in vetro in lastra tagliato, molato e lucidato. Spessore 2 cm in colore extra chiaro. Montatura in metallo cromato galvanizzato. Led integrato.

Wall lamp providing diffuse dimmable light. Sheet glass diffuser cut, ground and polished. 2 cm. thick in extra-clear colour. The frame is galvanised chrome-plated metal. LED integrated.

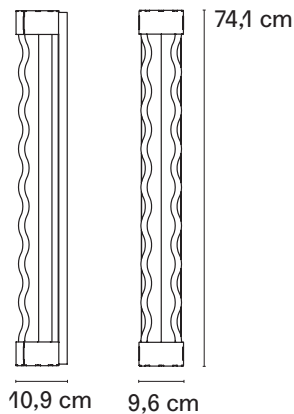

Codice Code	F446745550TCLE
Materiale Material	Vetro, Metallo Glass, Metal
Colore Color	● Trasparente, Cromo Transparent, Chrome
Sorgente luminosa Light source	LED 2x7W (2700K, CRI>90, 1550Lm)
Dimmerabile Dimmable	Si, a taglio di fase Yes, phase cut dimmer
Classe energetica Energy label	F





Studio Luca Guadagnino è uno studio di architettura d'interni con sede a Milano fondato dal regista Luca Guadagnino candidato premio Oscar nel 2017 e specializzato nel design contemporaneo mid-century italiano. Lo studio si occupa di progetti privati commissionati da clienti come Federico Marchetti, fondatore del gruppo Yoox Net-a-Porter e di progetti di retail per marchi del lusso tra i quali i nuovi negozi per il brand di skincare Aesop a Roma e a Londra e Redemption, brand di moda sostenibile, a New York. SLG è stato pubblicato su "By Design: The World's Best Contemporary Designers, un'autorevole guida che ha selezionato 100 tra i migliori e più creativi interior designers di oggi, edito da Phaidon nel 2021.

Studio Luca Guadagnino is a Milan-based interior architecture studio founded by 2017 Oscarnominated director Luca Guadagnino and specialising in contemporary mid-century Italian design. The studio handles private projects commissioned by clients such as Federico Marchetti, founder of the Yoox Net-a-Porter group, and retail projects for luxury brands including new shops for skincare brand Aesop in Rome and London and Redemption, a sustainable fashion brand, in New York. SLG was featured in By Design: The World's Best Contemporary Designers, an authoritative guide that selected 100 of today's best and most creative interior designers, published by Phaidon in 2021.

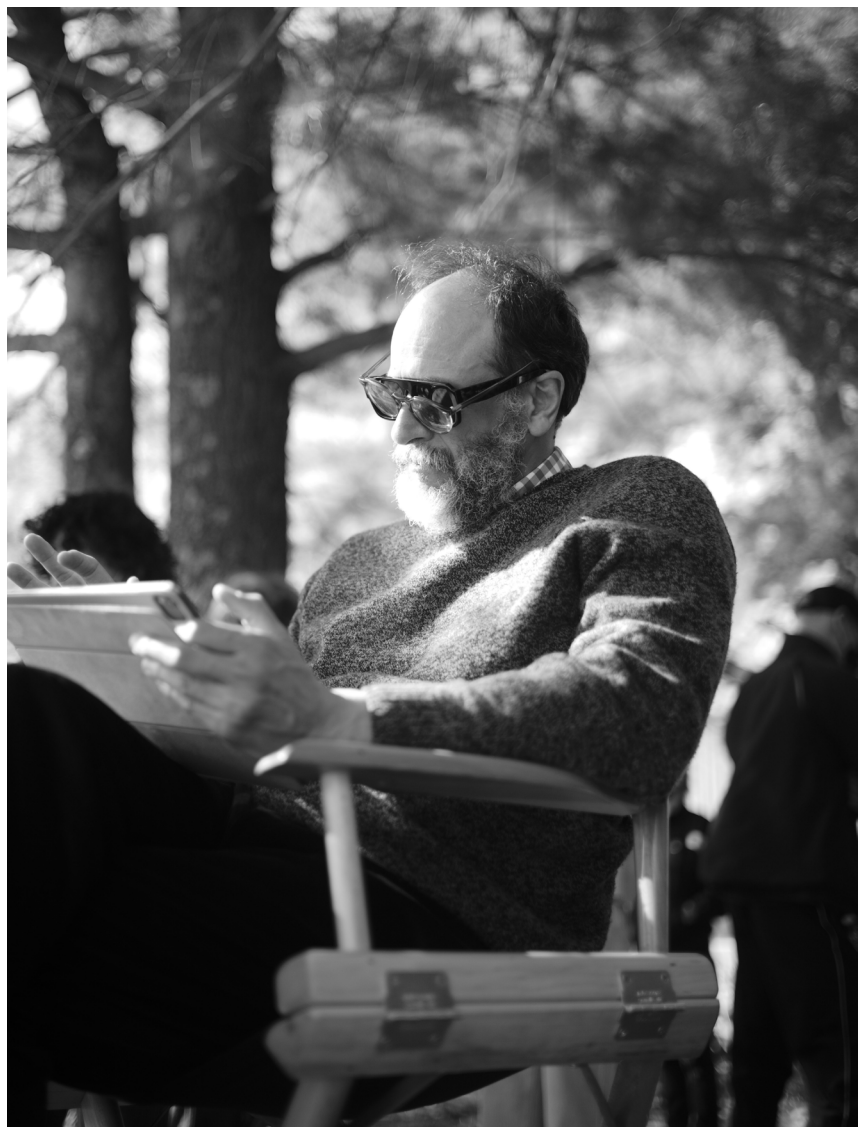



The relationship between light and glass continues in Gabriele and Oscar Buratti's research which started with the Equatore lamp and has now culminated in the new *THEA* lamp collection, also designed for FontanaArte.

The magic of the reflections that light gives off when it comes into contact with curved glass surfaces is the essential character of the lamp, thanks to its double diffuser: the first is small and internal, in white opaline glass, which has the function of diffusing the light homogeneously; the second diffuser, transparent or coloured, collects the light and multiplies it inside.



Continua il percorso di ricerca di Gabriele e Oscar Buratti sul tema del rapporto tra luce e vetro, iniziato con la lampada Equatore ed oggi approdato alla nuova collezione di lampade *THEA*, anche questa disegnata per FontanaArte.

La magia dei riflessi che la luce sprigiona al contatto con le superfici curve in vetro è il carattere essenziale della lampada, grazie alla doppia calotta: la prima piccola e interna, in vetro opalino bianco, che ha la funzione di diffondere la luce in modo omogeneo; la seconda calotta, trasparente o colorata, raccoglie la luce e la moltiplica al suo interno.

Tavolo, terra, parete, soffitto e sospensione, THEA è una famiglia di lampade trasversale alle tipologie di applicazione, pensata per un utilizzo sia negli ambienti domestici della casa che negli spazi più pubblici e contract dell'hotellerie, della ristorazione e del lavoro.

Table, floor, wall, ceiling and pendant, THEA is a family of lamps that covers all types of applications, designed for use both in the domestic environment of the home and in the more public and contract spaces of the hotel, restaurant and work sectors.



Lampada da tavolo a luce diffusa dimmerabile. Struttura in metallo galvanizzato. Diffusore interno in vetro soffiato bianco opalino acidato, diffusore esterno disponibile in vetro trasparente o colorato. Cavo di alimentazione, dimmer e spina neri. Alimentatore su spina con plug intercambiabili (UK, USA, Europa, Cina). Led integrato. La lampada mantiene memoria dell'ultima impostazione di dimmerazione.

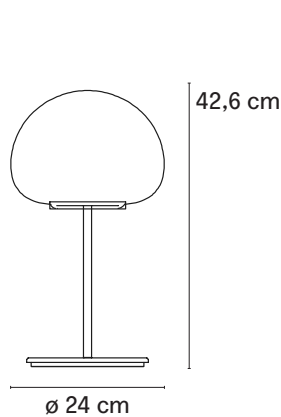



Codice Code	F444905550NFWL
Materiale Material	Vetro, Metallo Galvanizzato Glass, Galvanized Metal
Colore Color	 Nero lucido, Fumè Glossy black, Grey fumè
Sorgente luminosa Light source	LED 3,85W (3000K, CRI>90, 640Lm)
Dimmer incluso Dimmer included	Si Yes
Classe energetica Energy label	F



Table lamp providing diffuse dimmable light. Structure in galvanised metal. Inner diffuser in opal white blown acidetched glass, outer diffuser available in transparent or coloured glass. Black power cable, dimmer and plug. Power supply on interchangeable plugs (UK, USA, Europe, China). Integrated LED. The lamps keeps memory of last dimming setting.

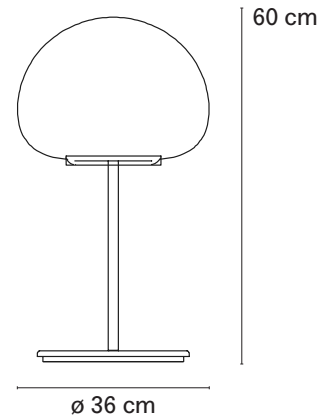

Codice Code	F444910550NFWL
Materiale Material	Vetro, Metallo Galvanizzato Glass, Galvanized Metal
Colore Color	 Nero lucido, Fumè Glossy black, Grey fumè
Sorgente luminosa Light source	LED 11,6W (3000K, CRI>90, 1596Lm)
Dimmer incluso Dimmer included	Si Yes
Classe energetica Energy label	F



Codice Code	F444905575RTWL
Materiale Material	Vetro, Metallo Galvanizzato Glass, Galvanized Metal
Colore Color	 Rame lucido, Trasparente Glossy copper, Transparent
Sorgente luminosa Light source	LED 3,85W (3000K, CRI>90, 640Lm)
Dimmer incluso Dimmer included	Si Yes
Classe energetica Energy label	F



Codice Code	F444910575RTWL
Materiale Material	Vetro, Metallo Galvanizzato Glass, Galvanized Metal
Colore Color	 Rame lucido, Trasparente Glossy copper, Transparent
Sorgente luminosa Light source	LED 11,6W (3000K, CRI>90, 1596Lm)
Dimmer incluso Dimmer included	Si Yes
Classe energetica Energy label	F



Lampada da terra a luce diffusa dimmerabile. Struttura in metallo galvanizzato. Diffusore interno in vetro soffiato bianco opalino acidato, diffusore esterno disponibile in vetro trasparente o colorato. Cavo di alimentazione, dimmer e spina neri. Alimentatore su spina con plug intercambiabili (UK, USA, Europa, Cina). Led integrato. La lampada mantiene memoria dell'ultima impostazione di dimmerazione. È possibile richiedere versione con Casambi integrato.

Floor lamp providing diffuse dimmable light. Structure in galvanised metal. Inner diffuser in opal white blown acid-etched glass, outer diffuser available in transparent or coloured glass. Black power cable, dimmer and plug. Power supply on interchangeable plugs (UK, USA, Europe, China). Integrated LED. The lamps keeps memory of last dimming setting. The product with integrated Casambi control system available on request.

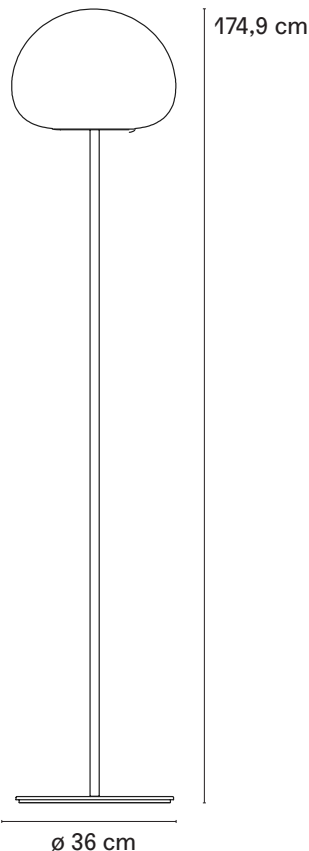

Codice Code	F444930550NFWL
Materiale Material	Vetro, Metallo Galvanizzato Glass, Galvanized Metal
Colore Color	● Nero lucido, Fumè Glossy black, Grey fumè
Sorgente luminosa Light source	LED 11,6W (3000K, CRI>90, 1596Lm)
Dimmer incluso Dimmer included	Si Yes
Classe energetica Energy label	F
 VETRO SOFFIATO BLOWN GLASS	 <small>Classe III</small> IP20

Codice Code	F444930575RTWL
Materiale Material	Vetro, Metallo Galvanizzato Glass, Galvanized Metal
Colore Color	● Rame lucido, Trasparente Glossy copper, Transparent
Sorgente luminosa Light source	LED 11,6W (3000K, CRI>90, 1596Lm)
Dimmer incluso Dimmer included	Si Yes
Classe energetica Energy label	F
 VETRO SOFFIATO BLOWN GLASS	 <small>Classe III</small> IP20

Lampada da parete/plafone a luce diffusa dimmerabile. Montatura in metallo verniciato. Diffusore interno in vetro soffiato bianco opalino acidato, diffusore esterno disponibile in vetro trasparente o colorato. Led integrato.

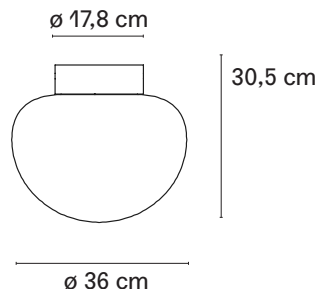
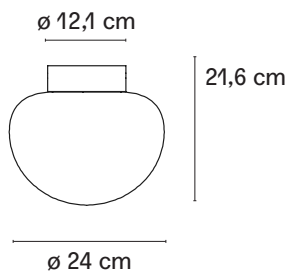

Wall/ceiling lamp providing diffuse dimmable light. Painted metal frame. Inner diffuser in opal white blown acid-etched glass, outer diffuser available in transparent or coloured glass. Integrated LED.



Codice Code	F444965550NFLE
Materiale Material	Vetro, Metallo Galvanizzato Glass, Galvanized Metal
Colore Color	 Nero lucido, Fumè Glossy black, Grey fumè
Sorgente luminosa Light source	LED 3,85W (3000K, CRI>90, 640Lm)
Dimmerabile Dimmable	Si, TRIAC Yes, TRIAC
Classe energetica Energy label	F
 VETRO SOFFIATO BLOWN GLASS	 IP40

Codice Code	F444970550NFLE
Materiale Material	Vetro, Metallo Galvanizzato Glass, Galvanized Metal
Colore Color	 Nero lucido, Fumè Glossy black, Grey fumè
Sorgente luminosa Light source	LED 11,6W (3000K, CRI>90, 1596Lm)
Dimmerabile Dimmable	Si, 1-10V / PUSH Yes, 1-10V / PUSH
Classe energetica Energy label	F
 VETRO SOFFIATO BLOWN GLASS	 IP40

Codice Code	F444965575RTLE
Materiale Material	Vetro, Metallo Galvanizzato Glass, Galvanized Metal
Colore Color	 Rame lucido, Trasparente Glossy copper, Transparent
Sorgente luminosa Light source	LED 3,85W (3000K, CRI>90, 640Lm)
Dimmerabile Dimmable	Si, TRIAC Yes, TRIAC
Classe energetica Energy label	F
 VETRO SOFFIATO BLOWN GLASS	 IP40

Codice Code	F444970575RTLE
Materiale Material	Vetro, Metallo Galvanizzato Glass, Galvanized Metal
Colore Color	 Rame lucido, Trasparente Glossy copper, Transparent
Sorgente luminosa Light source	LED 11,6W (3000K, CRI>90, 1596Lm)
Dimmerabile Dimmable	Si, 1-10V / PUSH Yes, 1-10V / PUSH
Classe energetica Energy label	F
 VETRO SOFFIATO BLOWN GLASS	 IP40

Lampada a sospensione a luce diffusa dimmerabile. Montatura in metallo galvanizzato. Diffusore interno in vetro soffiato bianco opalino acidato, diffusore esterno diponibile in vetro trasparente o fumè. Cavo di alimentazione nero. Rosone in metallo verniciato bianco. Led integrato.

Pendant lamp providing diffused dimmable light. Galvanised metal frame. Inner diffuser in opal white blown acid-etched glass, outer diffuser in available in transparent or coloured glass. Steel suspension cable. Black power cable. Metal ceiling rose painted white. Integrated LED



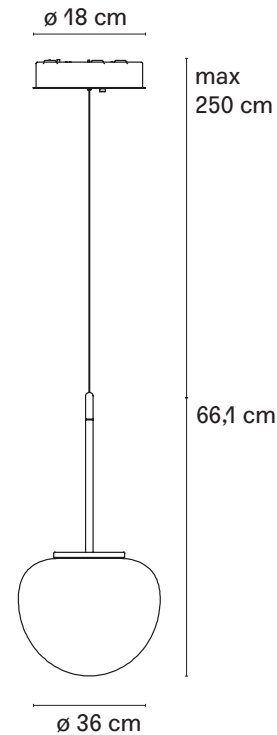
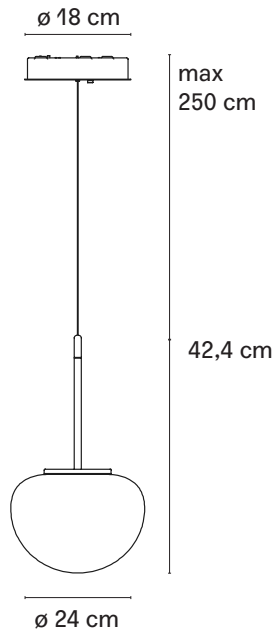

Codice Code	F444985550NFLE
Materiale Material	Vetro, Metallo Galvanizzato Glass, Galvanized Metal
Colore Color	 Nero lucido, Fumè Glossy black, Grey fumè
Sorgente luminosa Light source	LED 3,85W (3000K, CRI>90, 640Lm)
Dimmerabile Dimmable	Si, TRIAC Yes, TRIAC
Classe energetica Energy label	F
 VETRO SOFFIATO BLOWN GLASS	 IP40

Codice Code	F444990550NFLE
Materiale Material	Vetro, Metallo Galvanizzato Glass, Galvanized Metal
Colore Color	 Nero lucido, Fumè Glossy black, Grey fumè
Sorgente luminosa Light source	LED 11,6W (3000K, CRI>90, 1596Lm)
Dimmerabile Dimmable	Si, 1-10V / PUSH Yes, 1-10V / PUSH
Classe energetica Energy label	F
 VETRO SOFFIATO BLOWN GLASS	 IP40

Codice Code	F444985575RTLE
Materiale Material	Vetro, Metallo Galvanizzato Glass, Galvanized Metal
Colore Color	 Nero lucido, Fumè Glossy black, Grey fumè
Sorgente luminosa Light source	LED 3,85W (3000K, CRI>90, 640Lm)
Dimmerabile Dimmable	Si, TRIAC Yes, TRIAC
Classe energetica Energy label	F
 VETRO SOFFIATO BLOWN GLASS	 IP40

Codice Code	F444990550RTLE
Materiale Material	Vetro, Metallo Galvanizzato Glass, Galvanized Metal
Colore Color	 Nero lucido, Fumè Glossy black, Grey fumè
Sorgente luminosa Light source	LED 11,6W (3000K, CRI>90, 1596Lm)
Dimmerabile Dimmable	Si, 1-10V / PUSH Yes, 1-10V / PUSH
Classe energetica Energy label	F
 VETRO SOFFIATO BLOWN GLASS	 IP40



Gabriele Buratti, architetto e professore di architettura degli interni alla Facoltà del Design del Politecnico di Milano (2003-2010), e Oscar Buratti, architetto, formano lo studio di architettura e design Buratti Architetti. Diverse sono le scale del progetto su cui lo studio lavora in maniera trasversale, passando dall'architettura di edifici ed aree urbane a quella degli interni, dal design di mobili ed oggetti all'allestimento di mostre e showroom, in un percorso professionale intenso e variegato, dove si intrecciano, contaminandosi, i temi, i luoghi e le tipologie, le aziende e le persone, i materiali e le lavorazioni. Progettano edifici residenziali, commerciali ed industriali, interventi in centri storici e ristrutturazioni di complessi edilizi, ville ed interni di uffici, abitazioni, negozi e showroom, con l'intento di coniugare cultura e specializzazione professionale, sperimentazione e tecnica, visioni originali e qualità del prodotto. Nel settore del retail collaborano con brand prestigiosi per i quali realizzano boutique nelle più importanti città del mondo. Collaborano con alcune fra le più prestigiose e rinomate aziende del design per le quali hanno firmato progetti dell'illuminazione e dell'arredo venduti in tutto il mondo.

Gabriele Buratti, architect and professor of interior architecture at the Faculty of Design of Politecnico of Milan (2003-2010), e Oscar Buratti, architect, form the architecture and design studio Buratti Architetti. There are several scales of the project on which the studio works, from the architecture of buildings and urban areas to the interior of buildings, from the design of furniture and objects to exhibitions and showrooms, in an intense and varied professional path, where themes, places and typologies, companies and people, materials and workmanship, are intertwined and contaminating. They design residential, commercial and industrial buildings, interventions in historic centers and renovations of complex buildings, villas and interiors of offices, dwellings, shops and showrooms, with the aim of combining culture and professional specialization, experimentation and technique, original visions and product quality. In the retail field they collaborated with prestigious brands for which they created boutiques in the most important cities around the world. They collaborate with some of the most prestigious and renowned design companies for which they have signed lighting and furniture projects that are sold all over the world.





TUTTI designed by artist and designer Matilde Cassani for FontanaArte, tells a very topical story of contamination, of the union of similar yet opposite elements, of changing identities, of tastes and thoughts apparently opposed but belonging to the same individual; of peoples and cultures that mingle and become a single social nucleus, different in origin but united and for this reason extraordinary.



TUTTI disegnata per FontanaArte dall'artista e progettista Matilde Cassani, racconta una storia molto attuale di contaminazione, di unione fra elementi simili anche se opposti, di identità mutevoli, di gusti e pensieri apparentemente contrapposti ma che appartengono allo stesso individuo; di popoli e culture che si mischiano e diventano un unico nucleo sociale, diverso dalle origini ma unito e per questo straordinario.

Tutti è il trionfo degli opposti rappresentato da una serie di sagome appese che simboleggiano un mondo di contraddizioni e contrapposizioni: drappo religioso assieme allo scudetto della squadra di calcio; uomo e/o donna: gender fluidity; gonna e pantaloni; bottiglietta in plastica e pesce. Per citarne alcuni.

Tutti is the triumph of opposites represented by a series of hanging silhouettes symbolising a world of contradictions and contrasts: religious drape together with football team badge; man and/or woman: gender fluidity; skirt and trousers; plastic bottle and fish, to name a few.





Lampada a sospensione a luce diretta. L'effetto riflettente sugli elementi decorativi genera la diffusione della luce nell'ambiente circostante.
Rosone in metallo verniciato. Elementi decorativi in metallo galvanizzato dello stesso colore del cavo di sospensione. Led integrato.

Pendant lamp providing direct light. The reflective effect on the decorative elements generates the diffusion of the light in the room.
Painted metal ceiling rose. Galvanised metal decorative elements in the same colour as the suspension cable. Integrated LED.

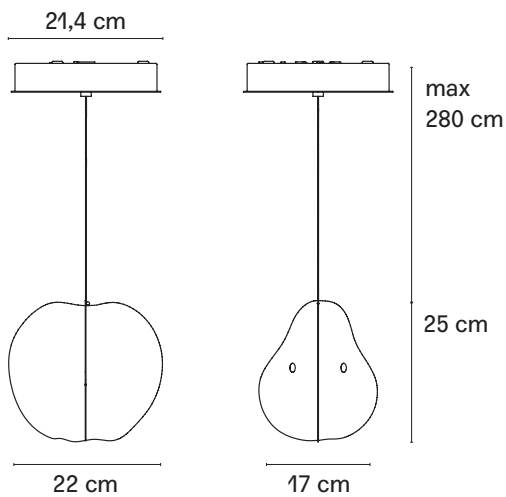
Mela / Pera - Apple / Pear



Codice Code	F446880240CRLE
Materiale Material	Metallo Metal
Colore Color	 Cromo Chrome
Sorgente luminosa Light source	12W LED (3000K, CRI>90, 1470Lm)
Dimmerabile Dimmable	Si, TRIAC Yes, TRIAC
Classe energetica Energy label	F
 IP20	

Codice Code	F446880240OOLE
Materiale Material	Metallo Metal
Colore Color	 Oro Gold
Sorgente luminosa Light source	12W LED (3000K, CRI>90, 1470Lm)
Dimmerabile Dimmable	Si, TRIAC Yes, TRIAC
Classe energetica Energy label	F
 IP20	

Mano aperta / Mano chiusa - Hand open / Hand close

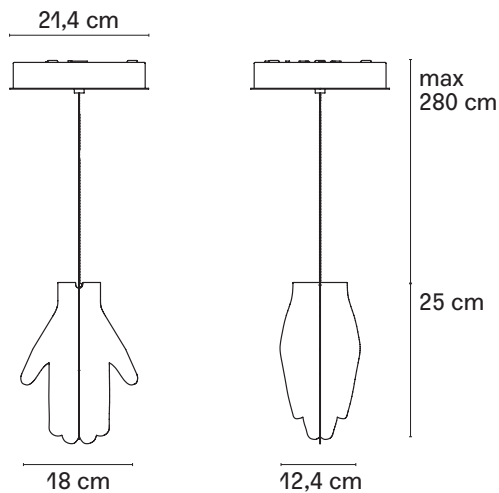

Codice Code	F446980240CRLE
Materiale Material	Metallo Metal
Colore Color	● Cromo Chrome
Sorgente luminosa Light source	12W LED (3000K, CRI>90, 1470Lm)
Dimmerabile Dimmable	Si, TRIAC Yes, TRIAC
Classe energetica Energy label	F
CE IP20	

Codice Code	F446980240OOLE
Materiale Material	Metallo Metal
Colore Color	● Oro Gold
Sorgente luminosa Light source	12W LED (3000K, CRI>90, 1470Lm)
Dimmerabile Dimmable	Si, TRIAC Yes, TRIAC
Classe energetica Energy label	F
CE IP20	

Uomo / Donna - Man / Woman

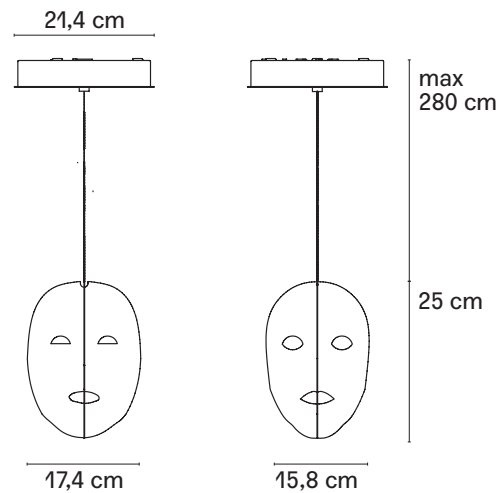

Codice Code	F447080240CRLE
Materiale Material	Metallo Metal
Colore Color	● Cromo Chrome
Sorgente luminosa Light source	12W LED (3000K, CRI>90, 1470Lm)
Dimmerabile Dimmable	Si, TRIAC Yes, TRIAC
Classe energetica Energy label	F
CE IP20	

Codice Code	F447080240OOLE
Materiale Material	Metallo Metal
Colore Color	● Oro Gold
Sorgente luminosa Light source	12W LED (3000K, CRI>90, 1470Lm)
Dimmerabile Dimmable	Si, TRIAC Yes, TRIAC
Classe energetica Energy label	F
CE IP20	

Bottiglia / Pesce - Bottle / Fish

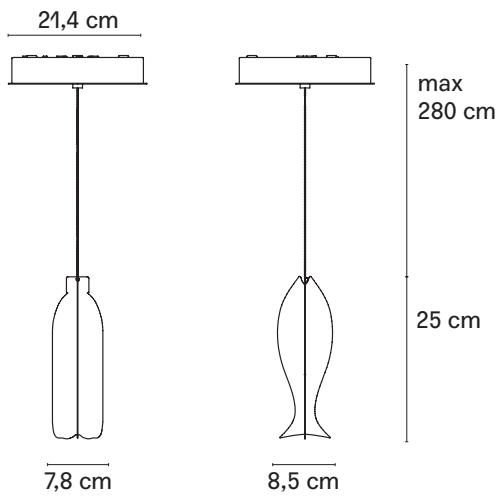

Codice Code	F447180240CRLE
Materiale Material	Metallo Metal
Colore Color	● Cromo Chrome
Sorgente luminosa Light source	12W LED (3000K, CRI>90, 1470Lm)
Dimmerabile Dimmable	Si, TRIAC Yes, TRIAC
Classe energetica Energy label	F
 IP20	

Codice Code	F447180240OOLE
Materiale Material	Metallo Metal
Colore Color	● Oro Gold
Sorgente luminosa Light source	12W LED (3000K, CRI>90, 1470Lm)
Dimmerabile Dimmable	Si, TRIAC Yes, TRIAC
Classe energetica Energy label	F
 IP20	

Foglie / Leaves

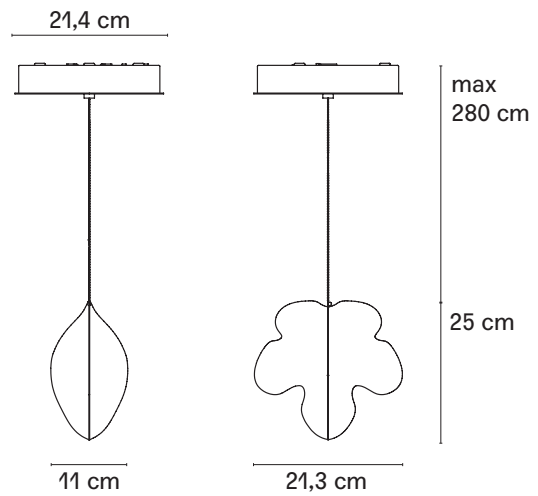

Codice Code	F447280240CRLE
Materiale Material	Metallo Metal
Colore Color	● Cromo Chrome
Sorgente luminosa Light source	12W LED (3000K, CRI>90, 1470Lm)
Dimmerabile Dimmable	Si, TRIAC Yes, TRIAC
Classe energetica Energy label	F
 IP20	

Codice Code	F447280240OOLE
Materiale Material	Metallo Metal
Colore Color	● Oro Gold
Sorgente luminosa Light source	12W LED (3000K, CRI>90, 1470Lm)
Dimmerabile Dimmable	Si, TRIAC Yes, TRIAC
Classe energetica Energy label	F
 IP20	

Sasso / Diamante - Stone / Diamond

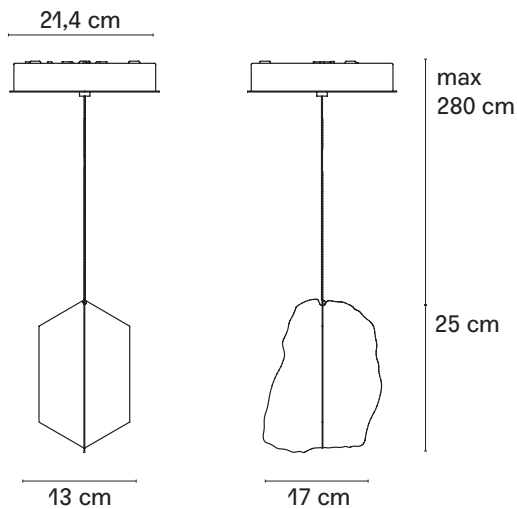

Codice Code	F447380240CRLE
Materiale Material	Metallo Metal
Colore Color	● Cromo Chrome
Sorgente luminosa Light source	12W LED (3000K, CRI>90, 1470Lm)
Dimmerabile Dimmable	Si, TRIAC Yes, TRIAC
Classe energetica Energy label	F
CE IP20	

Codice Code	F447380240OOLE
Materiale Material	Metallo Metal
Colore Color	● Oro Gold
Sorgente luminosa Light source	12W LED (3000K, CRI>90, 1470Lm)
Dimmerabile Dimmable	Si, TRIAC Yes, TRIAC
Classe energetica Energy label	F
CE IP20	

Drappo / Scudetto - Drape / Badge

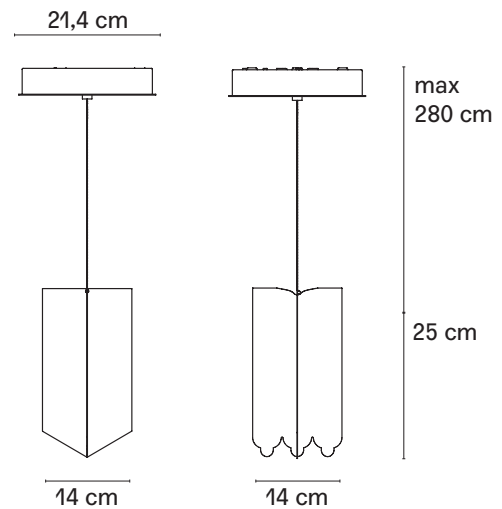

Codice Code	F447480240CRLE
Materiale Material	Metallo Metal
Colore Color	● Cromo Chrome
Sorgente luminosa Light source	12W LED (3000K, CRI>90, 1470Lm)
Dimmerabile Dimmable	Si, TRIAC Yes, TRIAC
Classe energetica Energy label	F
CE IP20	

Codice Code	F447480240OOLE
Materiale Material	Metallo Metal
Colore Color	● Oro Gold
Sorgente luminosa Light source	12W LED (3000K, CRI>90, 1470Lm)
Dimmerabile Dimmable	Si, TRIAC Yes, TRIAC
Classe energetica Energy label	F
CE IP20	

Gonna / Pantaloni - Skirt / Trousers

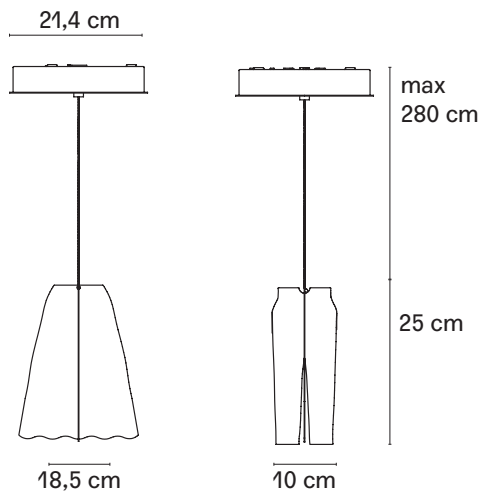

Codice Code	F447580240CRLE
Materiale Material	Metallo Metal
Colore Color	● Cromo Chrome
Sorgente luminosa Light source	12W LED (3000K, CRI>90, 1470Lm)
Dimmerabile Dimmable	Si, TRIAC Yes, TRIAC
Classe energetica Energy label	F

CE IP20

Codice Code	F447580240OOLE
Materiale Material	Metallo Metal
Colore Color	● Oro Gold
Sorgente luminosa Light source	12W LED (3000K, CRI>90, 1470Lm)
Dimmerabile Dimmable	Si, TRIAC Yes, TRIAC
Classe energetica Energy label	F

CE IP20

Lampada a sospensione multipla a luce diretta. L'effetto riflettente sugli elementi decorativi genera la diffusione della luce nell'ambiente circostante. Rosone in metallo verniciato nero. Elementi decorativi in metallo galvanizzato dello stesso colore del cavo di sospensione. Led integrato.

Multiple pendant lamp providing direct light. The reflective effect on the decorative elements generates the diffusion of the light in the room. Black painted metal ceiling rose. Galvanised metal decorative elements in the same colour as the suspension cable. Integrated LED.

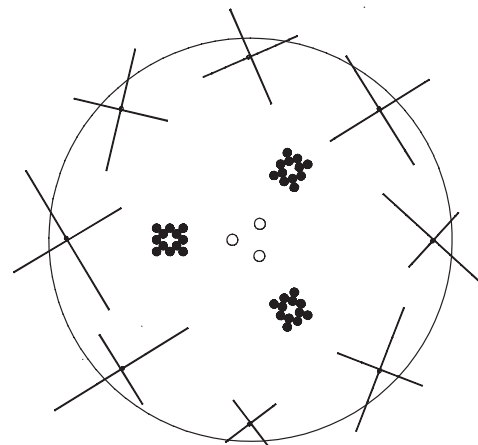
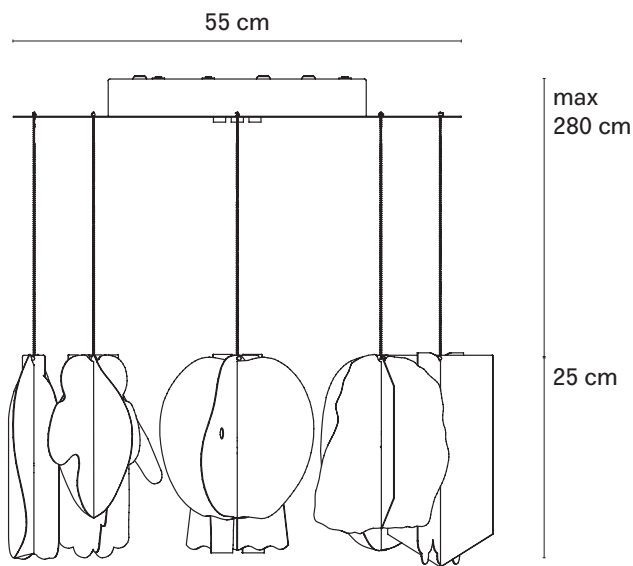

Codice Code	F446890240CRLE
Materiale Material	Metallo Metal
Colore Color	● Cromo Chrome
Sorgente luminosa Light source	3x12W LED (3000K, CRI>90, 4410Lm)
Dimmerabile Dimmable	Si, TRIAC Yes, TRIAC
Classe energetica Energy label	F
	CE IP20

Codice Code	F446890240OOLE
Materiale Material	Metallo Metal
Colore Color	● Oro Gold
Sorgente luminosa Light source	3x12W LED (3000K, CRI>90, 4410Lm)
Dimmerabile Dimmable	Si, TRIAC Yes, TRIAC
Classe energetica Energy label	F
	CE IP20

Matilde Cassani si muove in un'area di confine fra architettura, installazioni, ed event design. Il suo lavoro trova la propria origine nelle implicazioni spaziali del pluralismo culturale. I suoi lavori sono stati esposti in molte istituzioni e manifestazioni fra cui lo Storefront for Art and Architecture di New York (2011); tre edizioni della Biennale Architettura di Venezia (2012, 2014, 2018); Victoria and Albert Museum (2015); Triennale di Oslo (2016); Biennale di Architettura di Chicago (2017); Manifesta 12 (2018); Triennale di Milano (2019); Cassani ha insegnato in diverse università europee fra cui il Sandberg Instituut di Amsterdam, la Syracuse Architecture University di Firenze. Attualmente insegna alla NABA di Milano e alla AA, Architectural Association di Londra. Sue opere sono presenti nelle collezioni di diversi musei fra cui il Victoria and Albert Museum, il MAXXI e il Franz Hals Museum di Harleem.

Matilde Cassani moves on the border between architecture, installation and event design. Her practice deals with the spatial implications of cultural pluralism in the contemporary Western city. Her works have been exhibited in many institutions such as Storefront for Art and Architecture, New York (2011); Biennale Architettura di Venezia (2012, 2014, 2018); Victoria and Albert Museum (2015); Oslo Triennale (2016); Chicago Architecture Biennale (2017); Manifesta 12, Palermo (2018); Triennale di Milano (2019); She currently teaches at Naba in Milano and at the Architectural Association in London. Her works are present in several museum collections including Victoria and Albert Museum, il MAXXI e il Franz Hals Museum di Harleem.



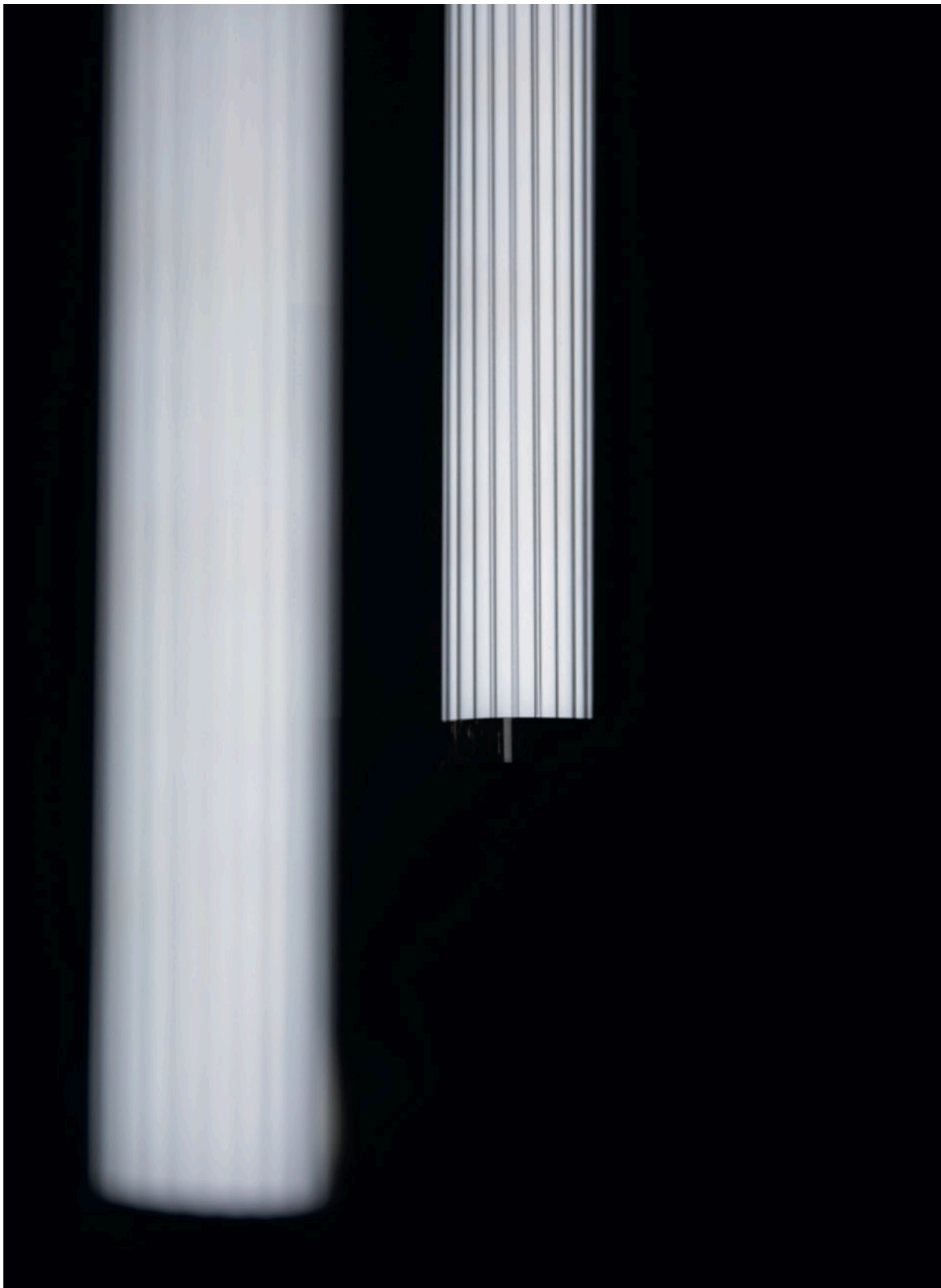

Just as the *OORT* cloud is the origin of millions of comet nuclei that illuminate the Firmament, so the modular lamp system from which it takes its name is the origin of an *infinite series of lighting solutions*. Oort, designed by Jacopo Roda, an engineer who has been a member of FontanaArte's R&D team for many years, consists of a uniform, flexible light line positioned inside an internally ribbed glass cylinder. These tubular elements can generate an infinite system of compositions and shapes, which can be combined to meet every architectural and aesthetic requirement.

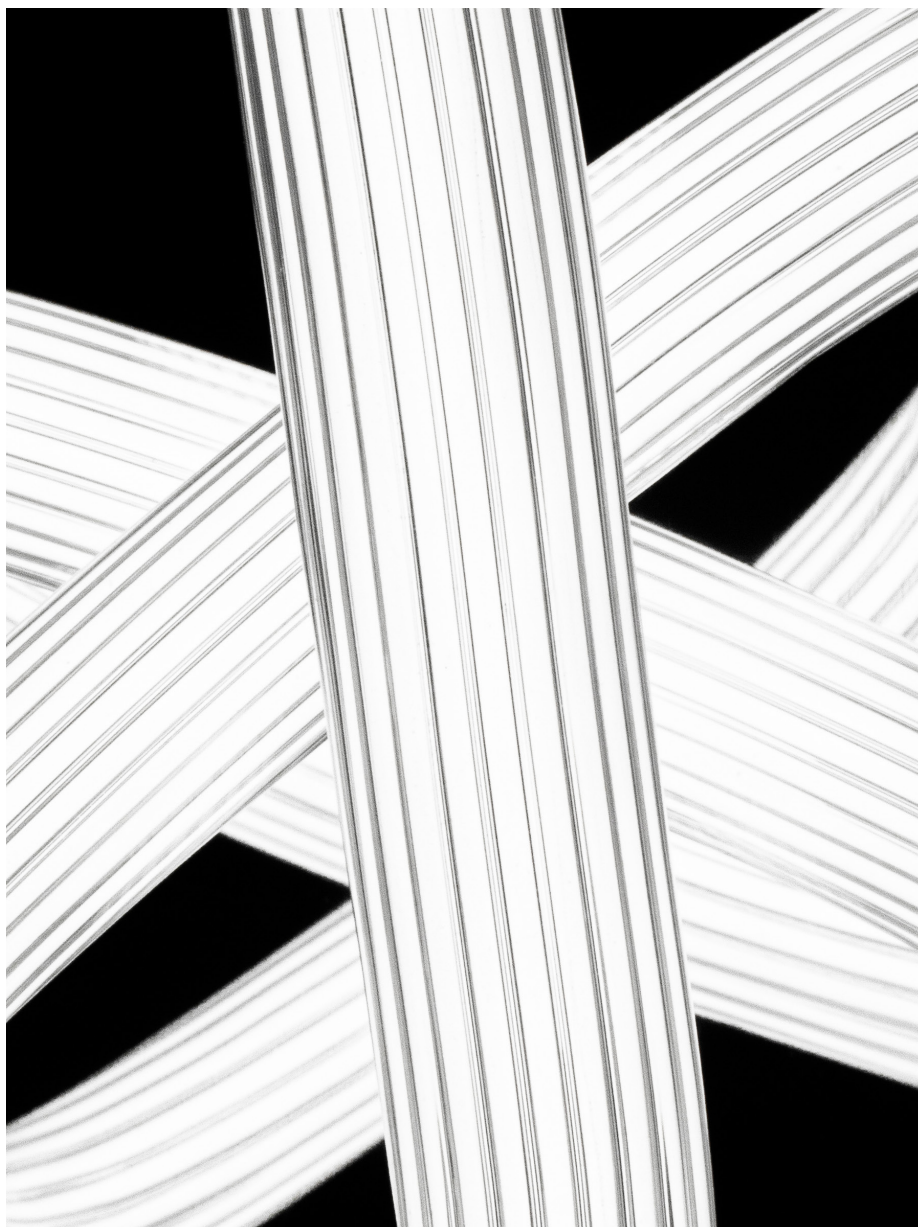

Come la nube di *OORT* è l'origine di milioni di nuclei di comete che con la loro scia illuminano il Firmamento, così il sistema di lampade componibile dalla quale prende il nome è l'origine di una *serie infinita di soluzioni luminose*. Oort, disegnata da Jacopo Roda, ingegnere che da anni fa parte del team Ricerca&Sviluppo di FontanaArte, è composta da una linea luminosa, uniforme e flessibile, posizionata all'interno di un cilindro di vetro rigato internamente. Questi elementi tubolari possono generare un sistema infinito di composizioni e forme, combinabili a piacimento per soddisfare ogni esigenza architettonica ed estetica.

Il sistema OORT è composto da elementi tubolari in vetro borosilicato all'interno dei quali sono collocati dei tubi flessibili luminosi a LED di ultima generazione, facilmente sostituibili, con emissione di luce a 360° perfettamente uniforme e certificati anche per ambienti esterni. Il vetro borosilicato è rigato internamente, accorgimento che valorizza la luce rendendola calda e accogliente, fa risaltare l'effetto di luci e ombre e consente una facile pulizia della superficie esterna liscia. La luce è diffusa e dimmerabile, disponibile a 3000K oppure Dim To Warm. Nei tubi Dim To Warm la temperatura di colore cambia, in funzione della dimmerazione, da 1800K sino a 4000K alla massima intensità. Il flusso è in funzione della dimmerazione ad un massimo di 1000Lm/m.

The OORT system is composed of tubular elements made of borosilicate glass. Inside them are flexible LED light tubes of the latest generation, easily replaceable, with perfectly uniform 360° light emission and certified also for outdoor use.

The borosilicate glass is ribbed on the inside, a feature that enhances the light by making it warm and welcoming, brings out the effect of light and shadow, and allows easy cleaning of the smooth outer surface. The light is diffuse, dimmable and available at 3000K or Dim To Warm which allows to change the colour temperature, by dimming, from minimum 1800K to 4000K at maximum intensity. The flux is dimmer-dependent to a maximum of approx 1000Lm/m.



La versione da tavolo è proposta con la base a specchio. Cavo di alimentazione, dimmer e spina neri. Alimentatore su spina con plug intercambiabili (UK - USA - Europa - Australia). Led integrato. La lampada mantiene memoria dell'ultima impostazione di dimmerazione.

The table version is offered with a mirror base. Black power cable, dimmer and plug. Plug-in power supply with interchangeable plugs (UK, USA, Europe, Australia). Integrated led. The lamp keeps memory of the last dimming setting.

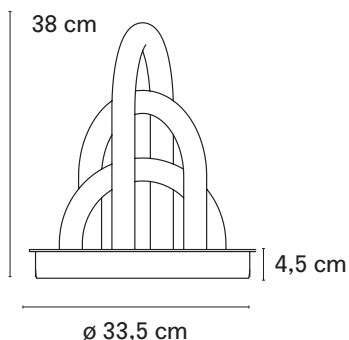

Codice Code	OORT00020
Materiale Material	Vetro, Metallo Glass, Metal
Colore Color	 Bianco, Specchio White, Mirror
Sorgente luminosa Light source	LED 8W + 12W + 16W (3000K, 3420Lm)
Dimmer incluso Dimmer included	Si Yes
Classe energetica Energy label	G
 ^{Classe II}  IP20	

Codice Code	OORT00021
Materiale Material	Vetro, Metallo Glass, Metal
Colore Color	 Bianco, Specchio White, Mirror
Sorgente luminosa Light source	LED 8W + 12W + 16W (DTW da 1800K a 4000K)
Dimmer incluso Dimmer included	Si Yes
Classe energetica Energy label	G
 ^{Classe II}  IP20	

A richiesta è possibile fornire il prodotto a 2700K / The product can be supplied at 2700K on request.

La versione terra-cielo è proposta con un contrappeso a terra e un aggancio nickel nero a soffitto che ne garantiscono la perfetta stabilità. Cavo di alimentazione, dimmer e spina neri. Alimentatore su spina con plug intercambiabili (UK - USA - Europa - Australia). Led integrato. La lampada mantiene memoria dell'ultima impostazione di dimmerazione.

The floor-to-ceiling version is offered with a counterweight on the floor and a black nickel hook on the ceiling that guarantee perfect stability. Black power cable, dimmer and plug. Plug-in power supply with interchangeable plugs (UK, USA, Europe, Australia). Integrated led. The lamp keeps memory of the last dimming setting.



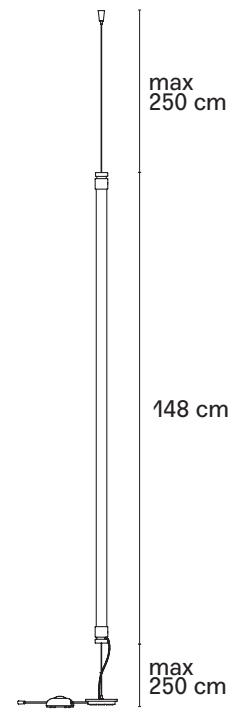
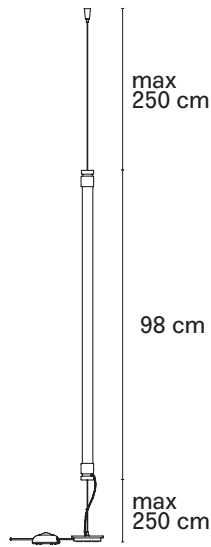

Codice Code	OORT00001
Materiale Material	Vetro, Metallo Galvanizzato Glass, Galvanized Metal
Colore Color	● Nichel nero Nickel black
Sorgente luminosa Light source	LED 18W (3000K, 1700Lm)
Dimmer incluso Dimmer included	Si Yes
Classe energetica Energy label	G
 IP20	

Codice Code	OORT00002
Materiale Material	Vetro, Metallo Galvanizzato Glass, Galvanized Metal
Colore Color	● Nichel nero Nickel black
Sorgente luminosa Light source	LED 28W (3000K, 2660Lm)
Dimmer incluso Dimmer included	Si Yes
Classe energetica Energy label	G
 IP20	

Codice Code	OORT00010
Materiale Material	Vetro, Metallo Galvanizzato Glass, Galvanized Metal
Colore Color	● Nichel nero Nickel black
Sorgente luminosa Light source	LED 18W (DTW da 1800K a 4000K)
Dimmer incluso Dimmer included	Si Yes
Classe energetica Energy label	G
 IP20	

Codice Code	OORT00011
Materiale Material	Vetro, Metallo Galvanizzato Glass, Galvanized Metal
Colore Color	● Nichel nero Nickel black
Sorgente luminosa Light source	LED 28W (DTW da 1800K a 4000K)
Dimmer incluso Dimmer included	Si Yes
Classe energetica Energy label	G
 IP20	

A richiesta è possibile fornire il prodotto a 2700K e Casambi integrato /
The product can be supplied at 2700K and Casambi control on request.

A richiesta è possibile fornire il prodotto a 2700K e Casambi integrato /
The product can be supplied at 2700K and Casambi control on request.

La versione parete/plafone è proposta con un attacco a parete/plafone ellittico a specchio. Led integrato.

The wall/ceiling version is offered with an elliptical mirrored wall/ceiling fitting. Integrated LED.



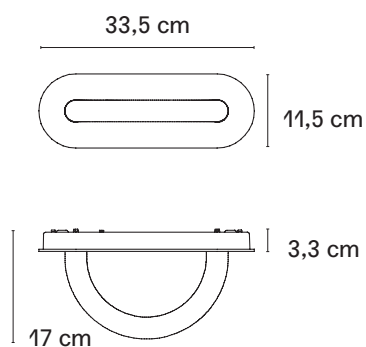

Codice Code	OORT00030
Materiale Material	Vetro, Metallo Glass, Metal
Colore Color	☉ Bianco, Specchio White, Mirror
Sorgente luminosa Light source	LED 8W (3000K, 760Lm)
Dimmerabile Dimmable	Si, 1-10V e PUSH Yes, 1-10V and PUS
Classe energetica Energy label	G

CE IP20*

Codice Code	OORT00031
Materiale Material	Vetro, Metallo Glass, Metal
Colore Color	☉ Bianco, Specchio White, Mirror
Sorgente luminosa Light source	LED 8W (DTW da 1800K a 4000K)
Dimmerabile Dimmable	Si, 1-10V e PUSH Yes, 1-10V and PUS
Classe energetica Energy label	G

CE IP20*

A richiesta è possibile fornire il prodotto a 2700K / The product can be supplied at 2700K on request.

*su richiesta IP44 dimmerabile Triac / Dimmable Triac IP44 on request

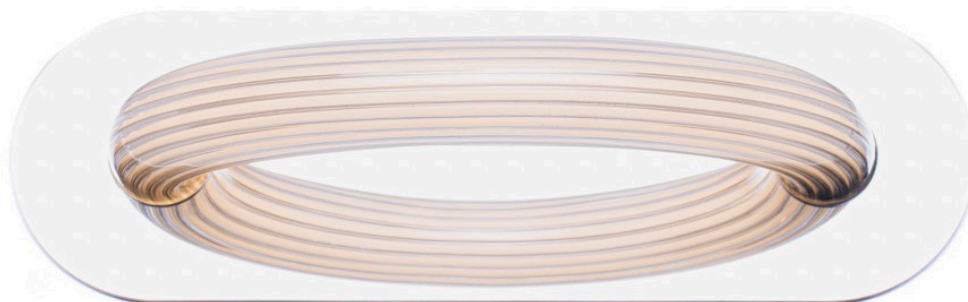

La versione plafone è proposta con attacco a specchio a forma circolare. Led integrato.

The ceiling version is offered with a circular mirror connection. Integrated LED.



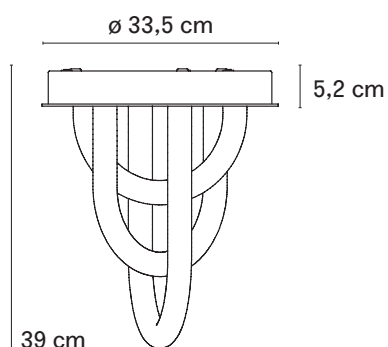

Codice Code	OORT00040
Materiale Material	Vetro, Metallo Glass, Metal
Colore Color	● Bianco, Specchio White, Mirror
Sorgente luminosa Light source	LED 8W + 12W + 16W (3000K, 3400Lm)
Dimmerabile Dimmable	Si, 1-10V e PUSH Yes, 1-10V and PUSH
Classe energetica Energy label	G

CE IP20

Codice Code	OORT00041
Materiale Material	Vetro, Metallo Glass, Metal
Colore Color	● Bianco, Specchio White, Mirror
Sorgente luminosa Light source	LED 8W + 12W + 16W (DTW da 1800K a 4000K)
Dimmerabile Dimmable	Si, 1-10V e PUSH Yes, 1-10V and PUS
Classe energetica Energy label	G

CE IP20

A richiesta è possibile fornire il prodotto a 2700K / The product can be supplied at 2700K on request.

La versione sospensione è disponibile nei modelli orizzontale e verticale, entrambi anche in composizioni multiple e di altezze diverse. Rosone per il collegamento elettrico a soffitto decentrato in finitura bianca. Led integrato.

The suspension version is available in horizontal and vertical models, both also in multiple compositions and different heights. Off-centre ceiling rose for electrical connection in white finish. Integrated LED.



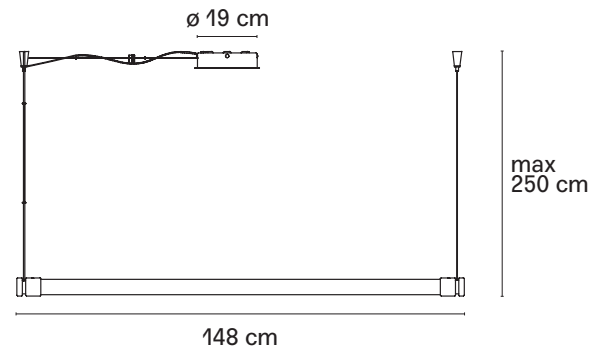
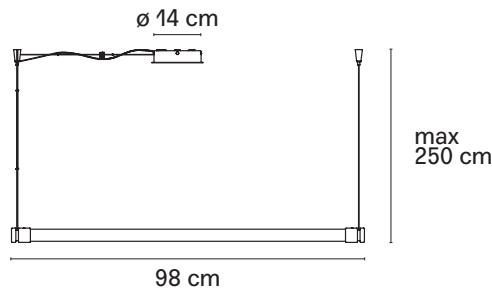

Codice Code	OORT00003
Materiale Material	Vetro, Metallo Galvanizzato Glass, Galvanized Metal
Colore Color	● Nichel nero Nickel black
Sorgente luminosa Light source	LED 18W (3000K, 1700Lm)
Dimmerabile Dimmable	Si, 1-10V/PUSH Yes, 1-10V/PUSH
Classe energetica Energy label	G
	CE IP20

Codice Code	OORT00004
Materiale Material	Vetro, Metallo Galvanizzato Glass, Galvanized Metal
Colore Color	● Nichel nero Nickel black
Sorgente luminosa Light source	LED 28W (3000K, 2660Lm)
Dimmerabile Dimmable	Si, 1-10V/PUSH Yes, 1-10V/PUSH
Classe energetica Energy label	G
	CE IP20

Codice Code	OORT00012
Materiale Material	Vetro, Metallo Galvanizzato Glass, Galvanized Metal
Colore Color	● Nichel nero Nickel black
Sorgente luminosa Light source	LED 18W (DTW da 1800K a 4000K)
Dimmerabile Dimmable	Si, 1-10V/PUSH Yes, 1-10V/PUSH
Classe energetica Energy label	G
	CE IP20

Codice Code	OORT00013
Materiale Material	Vetro, Metallo Galvanizzato Glass, Galvanized Metal
Colore Color	● Nichel nero Nickel black
Sorgente luminosa Light source	LED 28W (DTW da 1800K a 4000K)
Dimmerabile Dimmable	Si, 1-10V/PUSH Yes, 1-10V/PUSH
Classe energetica Energy label	G
	CE IP20

A richiesta è possibile fornire il prodotto a 2700K / The product can be supplied at 2700K on request.

A richiesta è possibile fornire il prodotto a 2700K / The product can be supplied at 2700K on request.

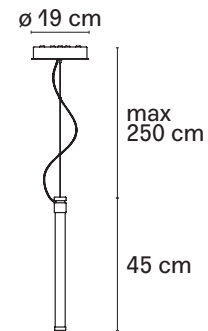

Codice Code	OORT00005
Materiale Material	Vetro, Metallo Galvanizzato Glass, Galvanized Metal
Colore Color	● Nichel nero Nickel black
Sorgente luminosa Light source	LED 8W (3000K, 760Lm)
Dimmerabile Dimmable	Si, 1-10V e PUSH Yes, 1-10V and PUSH
Classe energetica Energy label	G
 IP20	

Codice Code	OORT00014
Materiale Material	Vetro, Metallo Galvanizzato Glass, Galvanized Metal
Colore Color	● Nichel nero Nickel black
Sorgente luminosa Light source	LED 8W (DTW da 1800K a 4000K)
Dimmerabile Dimmable	Si, 1-10V e PUSH Yes, 1-10V and PUSH
Classe energetica Energy label	G
 IP20	

A richiesta è possibile fornire il prodotto a 2700K / The product can be supplied at 2700K on request.

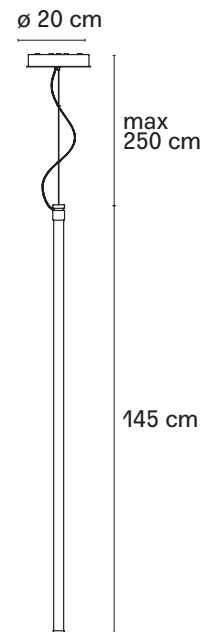
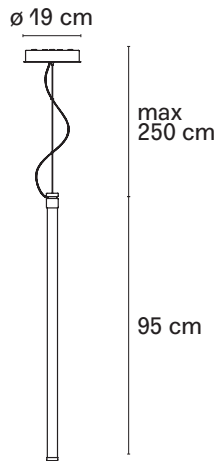

Codice Code	OORT00006
Materiale Material	Vetro, Metallo Galvanizzato Glass, Galvanized Metal
Colore Color	● Nichel nero Nickel black
Sorgente luminosa Light source	LED 18W (3000K, 1700Lm)
Dimmerabile Dimmable	Si, 1-10V e PUSH Yes, 1-10V and PUSH
Classe energetica Energy label	G
	CE IP20

Codice Code	OORT00007
Materiale Material	Vetro, Metallo Galvanizzato Glass, Galvanized Metal
Colore Color	● Nichel nero Nickel black
Sorgente luminosa Light source	LED 28W (3000K, 2660Lm)
Dimmerabile Dimmable	Si, DALI e PUSH Yes, DALI and PUSH
Classe energetica Energy label	G
	CE IP20

Codice Code	OORT00015
Materiale Material	Vetro, Metallo Galvanizzato Glass, Galvanized Metal
Colore Color	● Nichel nero Nickel black
Sorgente luminosa Light source	LED 18W (DTW da 1800K a 4000K)
Dimmerabile Dimmable	Si, 1-10V e PUSH Yes, 1-10V and PUSH
Classe energetica Energy label	G
	CE IP20

Codice Code	OORT00016
Materiale Material	Vetro, Metallo Galvanizzato Glass, Galvanized Metal
Colore Color	● Nichel nero Nickel black
Sorgente luminosa Light source	LED 28W (DTW da 1800K a 4000K)
Dimmerabile Dimmable	Si, DALI e PUSH Yes, DALI and PUSH
Classe energetica Energy label	G
	CE IP20

A richiesta è possibile fornire il prodotto a 2700K / The product can be supplied at 2700K on request.

A richiesta è possibile fornire il prodotto a 2700K / The product can be supplied at 2700K on request.

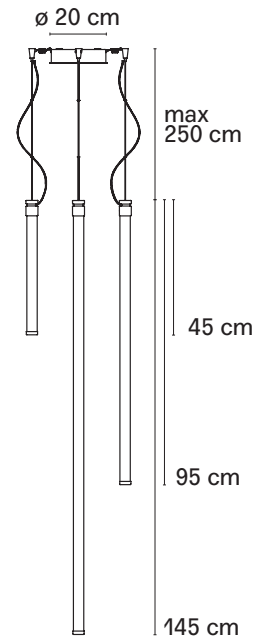
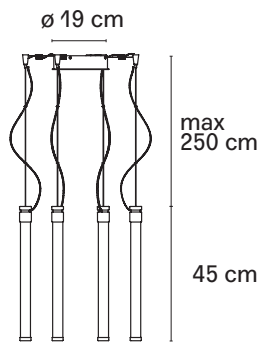

Codice Code	OORT00008
Materiale Material	Vetro, Metallo Galvanizzato Glass, Galvanized Metal
Colore Color	● Nichel nero Nickel black
Sorgente luminosa Light source	LED 4x8W (3000K, 3040Lm)
Dimmerabile Dimmable	Si, 1-10V e PUSH Yes, 1-10V and PUSH
Classe energetica Energy label	G
 IP20	

Codice Code	OORT00009
Materiale Material	Vetro, Metallo Galvanizzato Glass, Galvanized Metal
Colore Color	● Nichel nero Nickel black
Sorgente luminosa Light source	LED 8W + 18W + 28W (3000K, 5130Lm)
Dimmerabile Dimmable	Si, DALI e PUSH Yes, DALI and PUSH
Classe energetica Energy label	G
 IP20	

Codice Code	OORT00017
Materiale Material	Vetro, Metallo Galvanizzato Glass, Galvanized Metal
Colore Color	● Nichel nero Nickel black
Sorgente luminosa Light source	LED 4x8W (DTW da 1800K a 4000K)
Dimmerabile Dimmable	Si, 1-10V e PUSH Yes, 1-10V and PUSH
Classe energetica Energy label	G
 IP20	

Codice Code	OORT00018
Materiale Material	Vetro, Metallo Galvanizzato Glass, Galvanized Metal
Colore Color	● Nichel nero Nickel black
Sorgente luminosa Light source	LED 8W + 18W + 28W (DTW da 1800K a 4000K)
Dimmerabile Dimmable	Si, DALI e PUSH Yes, DALI and PUSH
Classe energetica Energy label	G
 IP20	

A richiesta è possibile fornire il prodotto a 2700K / The product can be supplied at 2700K on request.

A richiesta è possibile fornire il prodotto a 2700K / The product can be supplied at 2700K on request.



La collezione Oort è ora integrata dalla nuova versione studiata per ambienti esterni. Oort, nella versione outdoor, è trattata con vernici protettive adatte per ambienti esterni ed è proposta in 3 diverse altezze pensate per soluzioni di illuminazione più semplici, rappresentate dal paletto luminoso, oppure dalla forma ad arco per un effetto più scenografico lasciando all'utente la scelta di abbinarli fra loro e disegnare il proprio percorso luminoso.

The Oort collection is now complemented by the new version designed for outdoor environments. Oort, in its outdoor version, is treated with protective paints suitable for outdoor environments and is offered in 3 different sizes designed for simpler lighting solutions, represented by the light pole, or by the arch shape for a more scenic effect, leaving the user the choice of combining them and designing their own lighting path.



Lampada da terra per esterno. Tubo in vetro borosilicato rigato internamente, base e terminale in metallo verniciato nero micaceo.

Il sistema di connessione elettrico IP65 e i tiranti di fissaggio al terreno sono in dotazione alla lampada mentre il picchetto è ordinabile come accessorio (OORTPIC). La base può essere incassata. Led integrato.

A richiesta è possibile fornire il prodotto a 2700K.

Alimentatore non incluso.

Su specifica richiesta, è possibile ordinare il sistema 24V più adatto all'installazione.

Floor lamp for outdoor use. Tube made of internally ribbed borosilicate glass, base and finial made of metal painted in micaceous black.

The IP65 electrical connection system and ground fixing rods are supplied with the lamp, while spike can be ordered as accessory (OORTPIC). The base can be recessed. Integrated LED.

The product can be supplied at 2700K on request.

Power supply not included.

On specific request, it is possible to order the 24V system most suitable for the installation.

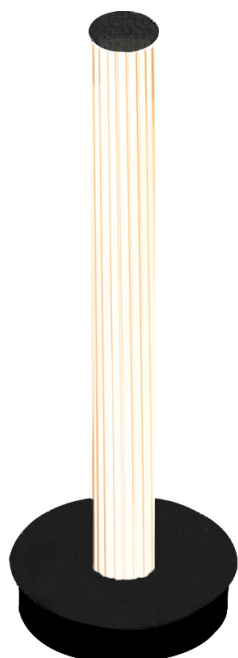
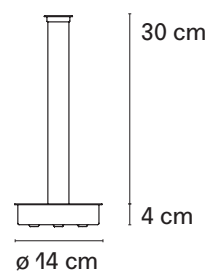

Codice Code	OORT05001
Materiale Material	Vetro, Metallo Glass, Metal
Colore Color	● Nero micaceo Micaceous black
Sorgente luminosa Light source	LED 6W (3000K, 570Lm)
Dimmerabile Dimmable	Si Yes
Classe energetica Energy label	G

Codice Code	OORT05011
Materiale Material	Vetro, Metallo Glass, Metal
Colore Color	● Nero micaceo Micaceous black
Sorgente luminosa Light source	LED 6W (DTW da 1800K a 4000K)
Dimmerabile Dimmable	Si Yes
Classe energetica Energy label	G

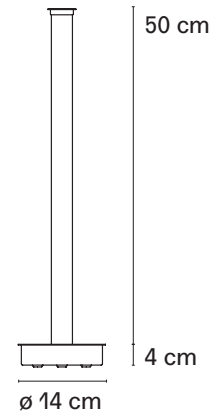
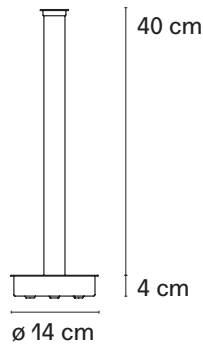

Codice Code	OORT05003
Materiale Material	Vetro, Metallo Glass, Metal
Colore Color	● Nero micaceo Micaceous black
Sorgente luminosa Light source	LED 8W (3000K, 760Lm)
Dimmerabile Dimmable	Si Yes
Classe energetica Energy label	G

Codice Code	OORT05005
Materiale Material	Vetro, Metallo Glass, Metal
Colore Color	● Nero micaceo Micaceous black
Sorgente luminosa Light source	LED 10W (3000K, 950Lm)
Dimmerabile Dimmable	Si Yes
Classe energetica Energy label	G

Codice Code	OORT05013
Materiale Material	Vetro, Metallo Glass, Metal
Colore Color	● Nero micaceo Micaceous black
Sorgente luminosa Light source	LED 8W (DTW da 1800K a 4000K)
Dimmerabile Dimmable	Si Yes
Classe energetica Energy label	G

Codice Code	OORT05015
Materiale Material	Vetro, Metallo Glass, Metal
Colore Color	● Nero micaceo Micaceous black
Sorgente luminosa Light source	LED 10W (DTW da 1800K a 4000K)
Dimmerabile Dimmable	Si Yes
Classe energetica Energy label	G

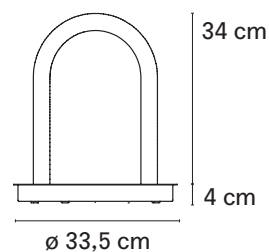

Codice Code	OORT05031
Materiale Material	Vetro, Metallo Glass, Metal
Colore Color	● Nero micaceo Micaceous black
Sorgente luminosa Light source	LED 16W (3000K, 1520Lm)
Dimmerabile Dimmable	Si Yes
Classe energetica Energy label	G

Codice Code	OORT05041
Materiale Material	Vetro, Metallo Glass, Metal
Colore Color	● Nero micaceo Micaceous black
Sorgente luminosa Light source	LED 16W (DTW da 1800K a 4000K)
Dimmerabile Dimmable	Si Yes
Classe energetica Energy label	G

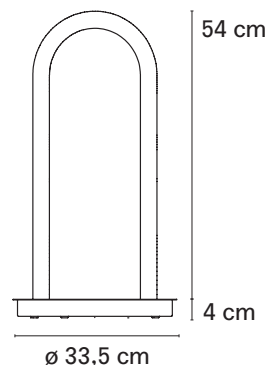
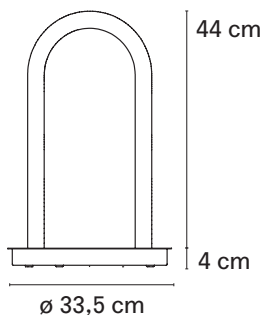

Codice Code	OORT05033
Materiale Material	Vetro, Metallo Glass, Metal
Colore Color	● Nero micaceo Micaceous black
Sorgente luminosa Light source	LED 20W (3000K, 1900Lm)
Dimmerabile Dimmable	Si Yes
Classe energetica Energy label	G

Codice Code	OORT05035
Materiale Material	Vetro, Metallo Glass, Metal
Colore Color	● Nero micaceo Micaceous black
Sorgente luminosa Light source	LED 24W (3000K, 2280Lm)
Dimmerabile Dimmable	Si Yes
Classe energetica Energy label	G

Codice Code	OORT05043
Materiale Material	Vetro, Metallo Glass, Metal
Colore Color	● Nero micaceo Micaceous black
Sorgente luminosa Light source	LED 20W (DTW da 1800K a 4000K)
Dimmerabile Dimmable	Si Yes
Classe energetica Energy label	G

Codice Code	OORT05045
Materiale Material	Vetro, Metallo Glass, Metal
Colore Color	● Nero micaceo Micaceous black
Sorgente luminosa Light source	LED 24W (DTW da 1800K a 4000K)
Dimmerabile Dimmable	Si Yes
Classe energetica Energy label	G

Jacopo Roda, laureato in Ingegneria Meccanica, e classe 1967, ha vissuto a Firenze dove ha respirato il mondo dell'arte e dell'artigianato. Nello stesso periodo nasce

la sua passione per la fotografia e per la luce, ritenendola un elemento fondamentale per le sue foto e trovando in essa il perfetto abbinamento tra arte e tecnica. Appassionato di illuminazione e di design, dopo alcune esperienze come progettista, nel 2006 approda in FontanaArte dove oggi ricopre il ruolo di Project Manager e dove ha sviluppato numerosi progetti di successo in collaborazione con i designer. La lunga storia dell'azienda, l'artigianalità della lavorazione del vetro e la cura dei dettagli, lo affascina e lo ispirano al punto da aver progettato per l'azienda il sistema modulare OORT che coniuga la lunga tradizione della lavorazione del vetro con la nuova tecnologia di tubi siliconici led flessibili.

A graduate in Mechanical Engineering, born in 1967, Jacopo Roda lived in Florence where he breathed in the world of art and craftsmanship. His passion for photography dates back to the same period, together with his interest for light considering it a fundamental element for his photos and finding in it the perfect combination of art and technique. Passionate about lighting and design, after some experience as a designer, he joined FontanaArte in 2006 where he now holds the position of Project Manager and where he has developed numerous successful projects in collaboration with designers. The history of the company, the craftsmanship of glass working and the attention to detail fascinated and inspired him to the point that he designed the OORT modular system for the company, which combines the long tradition of glass working with the new technology of flexible LED silicone tubes.



SEDE / HEADQUARTERS

FONTANAARTE SPA

Alzaia Trieste 49
I-20094 Corsico (MI)
Ph. +39 02 45121
Fax +39 02 4512660 / 990
info@fontanaarte.com
P.I.: 09632850963

www.fontanaarte.com
Instagram: fontanaarte

FontanaArte è azienda certificata
ISO 9001:2015 con DNV - GL. Certificato
nr. 178796-2015-AQ-ITA-ACCREDIA

FontanaArte has ISO 9001:2015
certification from the DNV - GL. Certificate
no. 178796-2015-AQ-ITA-ACCREDIA

1998
ADI Compasso d'Oro
Career Award



Membro di
Member of



Dal 1992 Fondazione Altagamma
riunisce i marchi dell'eccellenza italiana
famosi a livello internazionale.
Since 1992 the Altagamma Foundation
has gathered together high-end Italian
brands famous at international level.

Per qualsiasi ulteriore informazione o dettaglio, vi preghiamo di contattare il vostro referente commerciale FontanaArte di riferimento.

Il materiale grafico, schizzi e foto contenuti in questa presentazione sono a scopo puramente informativo. Si raccomanda di non divulgare prima del lancio ufficiale da parte dell'Azienda.

For any further information or details, please contact your FontanaArte's sales representative.

The graphic materials, sketches and photos contained in this presentation are for informational purpose only. It is recommended not to disclose before the official launch by the Company.